



**Transmitter
SITRANS P300**
with PROFIBUS PA communication

pressure
measurement

SIEMENS

Pressure transmitter

Transmitter SITRANS P300 with PROFIBUS- PA communication

Operating Instructions

<u>Introduction</u>	1
<u>General safety instructions</u>	2
<u>Description</u>	3
<u>Installation</u>	4
<u>Connecting</u>	5
<u>Operation</u>	6
<u>Operating functions over PROFIBUS</u>	7
<u>Configuration/projection</u>	8
<u>Commissioning</u>	9
<u>Error and system messages</u>	10
<u>Specifications</u>	11
<u>Dimension drawings</u>	12
<u>Appendix</u>	A
<u>List of Abbreviations/Acronyms</u>	B

Safety Guidelines

This manual contains notices you have to observe in order to ensure your personal safety, as well as to prevent damage to property. The notices referring to your personal safety are highlighted in the manual by a safety alert symbol, notices referring to property damage only have no safety alert symbol. These notices shown below are graded according to the degree of danger.



Danger

indicates that death or severe personal injury **will** result if proper precautions are not taken.



Warning

indicates that death or severe personal injury **may** result if proper precautions are not taken.



Caution

with a safety alert symbol, indicates that minor personal injury can result if proper precautions are not taken.

Caution

without a safety alert symbol, indicates that property damage can result if proper precautions are not taken.

Notice

indicates that an unintended result or situation can occur if the corresponding information is not taken into account.

If more than one degree of danger is present, the warning notice representing the highest degree of danger will be used. A notice warning of injury to persons with a safety alert symbol may also include a warning relating to property damage.

Qualified Personnel

The device/system may only be set up and used in conjunction with this documentation. Commissioning and operation of a device/system may only be performed by **qualified personnel**. Within the context of the safety notes in this documentation qualified persons are defined as persons who are authorized to commission, ground and label devices, systems and circuits in accordance with established safety practices and standards.

Prescribed Usage

Note the following:



Warning

This device may only be used for the applications described in the catalog or the technical description and only in connection with devices or components from other manufacturers which have been approved or recommended by Siemens. Correct, reliable operation of the product requires proper transport, storage, positioning and assembly as well as careful operation and maintenance.

Trademarks

All names identified by ® are registered trademarks of the Siemens AG. The remaining trademarks in this publication may be trademarks whose use by third parties for their own purposes could violate the rights of the owner.

Copyright Siemens AG 2005. All rights reserved.

The distribution and duplication of this document or the utilization and transmission of its contents are not permitted without express written permission. Offenders will be liable for damages. All rights, including rights created by patent grant or registration of a utility model or design, are reserved.

Disclaimer of Liability

We have reviewed the contents of this publication to ensure consistency with the hardware and software described. Since variance cannot be precluded entirely, we cannot guarantee full consistency. However, the information in this publication is reviewed regularly and any necessary corrections are included in subsequent editions.

Siemens AG
Automation and Drives
Postfach 4848, 90327 Nuremberg, Germany

Siemens AG 2005
Technical data subject to change

Table of contents

1	Introduction	1-1
1.1	Purpose of this documentation	1-1
1.2	Change history	1-1
1.3	Further information.....	1-1
2	General safety instructions	2-1
2.1	General information	2-1
2.2	Correct usage.....	2-1
2.3	Laws and directives	2-1
2.4	Measures	2-2
2.5	Qualified Personnel.....	2-3
3	Description	3-1
3.1	System configuration	3-1
3.2	Applications.....	3-2
3.3	Operation	3-3
3.4	Structure.....	3-3
3.5	Structure of the nameplate.....	3-4
3.6	Mode of operation	3-5
3.6.1	Overview of mode of operation	3-5
3.6.2	Operation of the electronics	3-6
3.6.3	Measuring cell operation	3-7
3.7	SIMATIC PDM.....	3-11
3.8	PROFIBUS.....	3-12
3.8.1	Overview	3-12
3.8.2	Transmission technology	3-12
3.8.3	Topology	3-12
3.8.4	Properties of PROFIBUS PA	3-14
4	Installation	4-1
4.1	Safety information for installation.....	4-1
4.2	Installing gauge and absolute pressure versions.....	4-3
4.2.1	Information for installing gauge and absolute pressure versions	4-3
4.2.2	Installation for gauge and absolute pressure.....	4-4
4.3	Installation for level version.....	4-4
4.3.1	Information for installing level version.....	4-4
4.3.2	Installation for level	4-6
5	Connecting	5-1

5.1	Connection safety information	5-1
5.2	Connecting the transmitter	5-2
6	Operation.....	6-1
6.1	Overview of operation	6-1
6.2	Safety information for operation	6-2
6.3	Information on operation	6-2
6.4	Digital display	6-3
6.4.1	Elements of the digital display	6-3
6.4.2	Units display	6-4
6.4.3	Error display	6-4
6.4.4	Mode display	6-5
6.4.5	Status display	6-6
6.5	Local operation.....	6-6
6.5.1	Local control elements	6-6
6.5.2	Operating via keys	6-8
6.5.3	Adjusting electrical damping	6-10
6.5.4	Zero point calibration.....	6-10
6.5.5	Locking keys	6-11
6.5.6	Releasing key or function lock	6-12
6.5.7	Source of measured value display	6-13
6.5.8	Unit	6-15
6.5.9	Bus address	6-18
6.5.10	Device operation type	6-19
6.5.11	Position of the decimal point	6-21
6.5.12	Display of the zero-point adjustment.....	6-22
6.5.13	LO calibration	6-22
6.5.14	HI calibration	6-24
7	Operating functions over PROFIBUS.....	7-1
7.1	Communication structure for PROFIBUS PA.....	7-1
7.1.1	Overview	7-1
7.1.2	Block model for collection and processing of measured values	7-1
7.1.3	Pressure transducer block	7-4
7.1.3.1	Pressure transducer block (transducer block 1)	7-4
7.1.3.2	Linearization type function group	7-6
7.1.3.3	Units of the pressure transducer block	7-8
7.1.4	Electronics temperature transducer block.....	7-8
7.1.5	Analog input function block	7-9
7.1.6	Totalizer function block	7-10
7.2	Overview of operating functions.....	7-10
7.3	Measurement	7-10
7.4	Settings	7-11
7.4.1	Overview of settings	7-11
7.4.2	Settings	7-11
7.4.3	Pressure measurement.....	7-11
7.4.4	Fill level measurement	7-12
7.4.5	Flow measurement.....	7-15
7.4.6	Adjusting to a desired process value	7-15
7.5	Electrical damping	7-17
7.6	Key lock and write protection	7-17

7.7	Warning and alarm limits	7-18
7.8	Failure behavior	7-20
7.8.1	Overview of failure behavior	7-20
7.8.2	Output	7-20
7.9	Diagnostic functions	7-20
7.9.1	Operating hours counter	7-20
7.9.2	Calibration interval and service interval	7-20
7.9.3	Clearing warning	7-21
7.9.4	Clearing the alarm	7-22
7.9.5	Min/max pointer	7-22
7.10	Simulation	7-23
7.10.1	Overview of simulation	7-23
7.10.2	Simulating output	7-24
7.10.3	Simulating input	7-24
7.10.4	Simulating the pressure sensor	7-24
7.10.5	Simulating sensor and electronics temperature	7-26
7.11	Calibrating the sensor	7-26
7.12	Correcting for positional error	7-27
7.13	Resetting	7-28
7.13.1	Resetting to delivery state	7-28
7.13.2	Warm start/restart	7-28
7.13.3	Resetting the PROFIBUS address	7-28
8	Configuration/projection	8-1
8.1	Cyclical data transfer	8-1
8.2	Configuration	8-1
8.2.1	Overview of configuration	8-1
8.2.2	Configuration of user data	8-2
8.2.3	Transmission of user data over PROFIBUS	8-3
8.2.4	Status	8-4
8.2.5	Diagnosis	8-4
8.3	Acyclic data transfer	8-6
9	Commissioning	9-1
9.1	Safety instructions for commissioning	9-1
9.2	Instructions for commissioning	9-2
9.3	Introduction to commissioning	9-3
9.4	Commissioning with steam or liquid	9-3
9.5	Commissioning for gases	9-5
10	Error and system messages	10-1
10.1	Errors	10-1
11	Specifications	11-1
11.1	SITRANS P300 gauge pressure / absolute pressure	11-1
11.2	SITRANS P300 gauge pressure / absolute pressure (flush-mounted)	11-6
12	Dimension drawings	12-1
12.1	SITRANS P300 gauge pressure / absolute pressure	12-1

Table of contents

12.2	SITRANS P300 gauge pressure / absolute pressure (flush-mounted).....	12-2
12.3	Flanges as per EN and ASME	12-3
12.4	F&B and pharma flange	12-4
12.5	Bioconnect/Biocontrol	12-5
12.6	PMC Style	12-7
A	Appendix	A-1
A.1	Certifications	A-1
A.2	Literature and catalogs.....	A-1
A.3	Overview of status codes	A-2
B	List of Abbreviations/Acronyms	B-1
B.1	Abbreviations for pressure transmitter overall	B-1
	Glossary	Glossary-1
	Index	

Tables

Table 6-1	Operating functions	6-2
Table 6-2	Meaning of the arrow displays	6-6
Table 6-3	Operating functions via keys	6-7
Table 6-4	Meaning of the lock modes	6-12
Table 6-5	Measurement type "Pressure"	6-13
Table 6-6	Measurement type "Level"	6-14
Table 6-7	Measurement type "Volume"	6-14
Table 6-8	Unit for pressure (P)	6-16
Table 6-9	Unit for volume (V)	6-16
Table 6-10	Unit for level (L).....	6-17
Table 6-11	Unit for mass (M).....	6-17
Table 6-12	Unit for temperature (T).....	6-17
Table 6-13	Unit for user-specific (U)	6-18
Table 6-14	Device operation type	6-19
Table 6-15	Device master data file.....	6-20
Table 7-1	Connection between blocks	7-3
Table 7-2	Display on digital display.....	7-4
Table 7-3	Available linearization functions.....	7-7
Table 7-4	Overview of available units	7-8
Table 7-5	Keypad locks	7-17
Table 7-6	Combined blocks.....	7-18
Table 7-7	Limits and status displays	7-18

Table 7-8	Failure behavior of the analog input function block	7-20
Table 8-1	User data dependent on the selected function block.....	8-2
Table 8-2	User data, dependent on selected additional function in the totalizer output function block.....	8-3
Table 8-3	IEEE standard floating point representation of the measured value	8-3
Table 8-4	Example status code.....	8-4
Table 8-5	Diagnostic messages.....	8-5
Table 10-1	Error message.....	10-1
Table A-1	Status code	A-2
Table B-1	Variables	B-1
Table B-2	Units	B-1
Table B-3	Other abbreviations.....	B-1

Introduction

1.1 Purpose of this documentation

These instructions contain all the information you need for commissioning and using the transmitter.

It is aimed both at persons mechanically installing the device, connecting it electronically, configuring the parameters and commissioning it as well as service and maintenance engineers.

1.2 Change history

Currently released versions of these instructions:

Edition	Comment	Firmware identifier, nameplate	System integration	Installation path for PDM
05/2005	First edition	FW: 0300.01.08	PDM V 6.00; Dev. R.1 DD Rev.1	SITRANS P300
06/2005	02	FW: 0300.01.08	PDM V 6.00; Dev. R.1 DD Rev.1	SITRANS P300

1.3 Further information

Information

The contents of these instructions shall not become part of or modify any prior or existing agreement, commitment or relationship. All commitments on the part of Siemens AG are contained in the respective sales contract which also contains the complete and solely applicable warranty conditions. Any statements contained herein do not create new warranties or modify the existing warranty.

The content reflects the technical status for printing. We reserve the right to make technical changes in the course of further development.

References

If there are references to further information on an aspect described here, these will always be found at the end of a chapter under "See also".

Offices

If you need more information or have particular problems which are not covered sufficiently by the operating instructions, contact your local Siemens office. You will find your local Siemens office on the Internet under:

www.siemens.de/prozessinstrumentierung

Click on "Contact" and select your closest town.

Product information on the Internet

The operating instructions are a constituent part of the enclosed CD "sitrans p TRANSMITTERS" (order number A5E00090345) and is available on the Internet at:

www.siemens.de/sitransp

Click on "More Info" and "-> Operating instructions and manuals".

On the enclosed CD, you will find an extract of the catalog FI 01 "Field devices for process automation" with the current order data. The entire FI 01 catalog is also available at the above Web address.

General safety instructions

2.1 General information

This device left the factory free from safety problems. In order to maintain this status and to ensure safe operation of the device, please observe the safety information and warnings contained in these instructions.

2.2 Correct usage

The device may only be used for the purposes specified in these instructions.

Insofar as they are not expressly stated in these instructions, all changes to the device are the sole responsibility of the user.

2.3 Laws and directives

The regulations of the test certification valid in your country are to be observed.

Electrical connection in hazardous zones with explosive atmospheres

The national directives and laws for hazardous areas valid in your country must be observed for electrical connection. For example, in Germany these are:

- Operational safety regulations
- Directive for the installation of electrical systems in hazardous areas DIN EN 60079-14 (previously VDE 0165, T1)

2.4 Measures

For the sake of safety, the following precautions must be observed:



Warning

Type of protection "pressure-proof encapsulation"

Devices with "pressure-proof encapsulation" protection may only be opened when off circuit.

"Intrinsically safe" protection type

"Intrinsically-safe" devices lose their certification as soon as they are operated on circuits which do not correspond with the test certification valid in their country.

Protection type "limited energy" nL (zone 2)

Devices with "limited energy" may be connected and disconnected while in operation.

Protection type "non-sparking" nA (zone 2)

Devices with "non-sparking" protection may only be connected and disconnected when off circuit.



Warning

Exposure to aggressive and hazardous media

The device can be operated both at high pressure and with aggressive and hazardous media. Therefore, improper use of this device may lead to serious injury and or considerable damage to property. Above all, it must be noted when the device was in use and is to be exchanged.



Caution

Electrostatic Sensitive Devices (ESD)

This device contains electrostatic sensitive devices. Electrostatic sensitive devices may be destroyed by voltages that are undetectable to a human. Voltages of this kind occur as soon as a component or an assembly is touched by a person who is not grounded against static electricity. The damage to a module as a result of overvoltage cannot usually be detected immediately. It may only become apparent after a long period of operation.

2.5 Qualified Personnel

"Qualified personnel" means those who are familiar with the installation, mounting, commissioning and operation of the product. They must have the following, appropriate qualifications for their activities:

- Training or instruction/authorization in operating and maintaining devices and systems according to the safety regulations for electrical circuits, high pressures and aggressive as well as hazardous media.
- For explosion-proof devices: Training or instruction/authorization in carrying out work on electrical circuits for hazardous systems.
- Training and instruction in maintenance and use of adequate safety equipment according to safety regulations.
- Should be trained in first aid.

Description

3.1 System configuration

Overview

The pressure transmitter can be used in a number of system configurations:
We recommend use as a part of a complex system environment, e.g. SIMATIC S7.

System communication

Communication is via the PROFIBUS-PA protocol, using:

- SIMATIC PDM
- Control system communicating over the PROFIBUS, e.g. SIMATIC S7

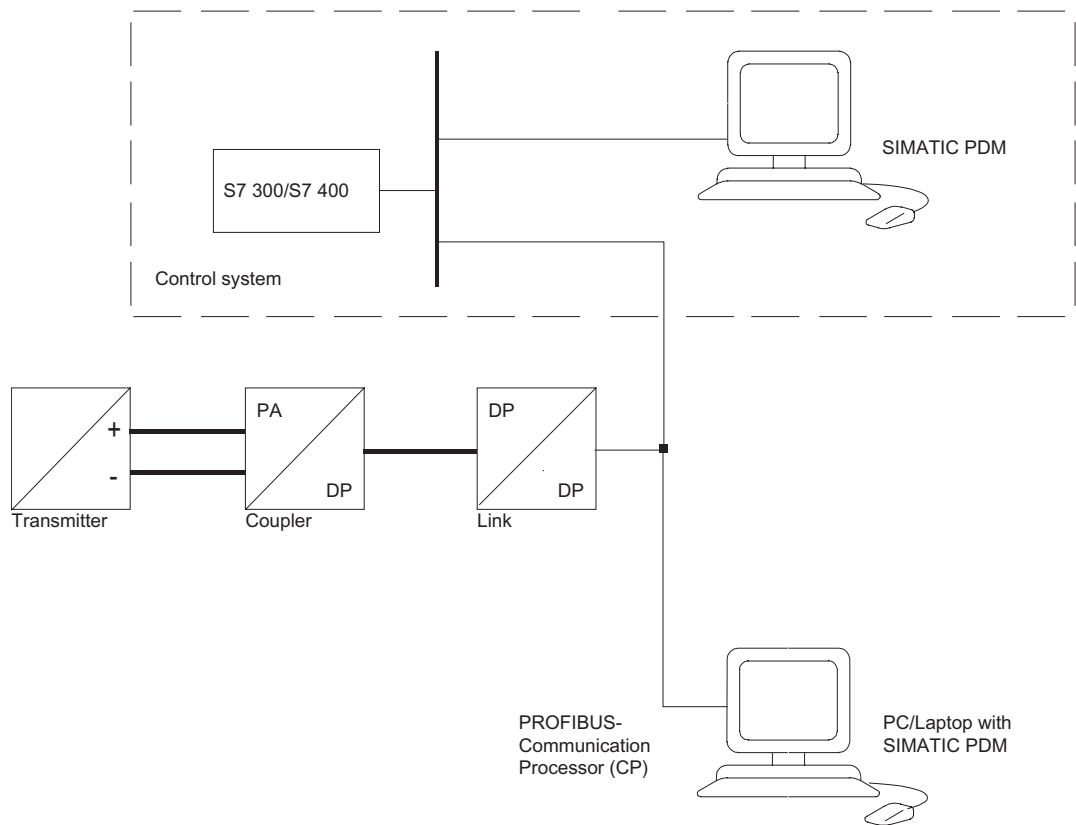

Figure 3-1 Possible system configurations

3.2 Applications

Overview

The pressure transmitter is available in the gauge pressure and absolute pressure versions. The output signal is a PROFIBUS-PA signal linearly proportional to the input pressure. The pressure transmitter measures aggressive, non-aggressive and hazardous gases, vapors and liquids.

It can be used for the following measurement types:

- Gauge pressure
- Absolute pressure

With appropriate parameter settings, it can also be used for the following additional measurement types:

- Level
- Volume
- Mass

The "intrinsically-safe" EEx version of the transmitter can be installed in hazardous areas (zone 1). The devices have an EC type examination certificate and comply with the appropriate harmonized European CENELEC standards .

Gauge pressure

This version measures aggressive, non-aggressive and hazardous gases, vapors and liquids.

The smallest measuring range is 8 mbar g (0.12 psi g), the largest 400 bar g (5802 psi g).

Level

With appropriate parameter settings, the gauge pressure version measures the level of aggressive, non-aggressive and hazardous liquids.

The level can be measured in an open container.

The parts in contact with the measured medium are made of various materials, depending on corrosion resistance requirements.

Absolute pressure

This version measures the absolute pressure of aggressive, non-aggressive and hazardous gases, vapors and liquids.

The smallest measuring range is 8 mbar a (0.12 psi a), the largest 30 bar a (435 psi a).

3.3 Operation

Overview

You can operate the basic settings of the pressure transmitter using the buttons on the device. The entire range of settings can be operated via PROFIBUS-PA communication.

3.4 Structure

Overview

The device comprises:

- Electronics
- Housing
- Measuring cell

3.5 Structure of the nameplate

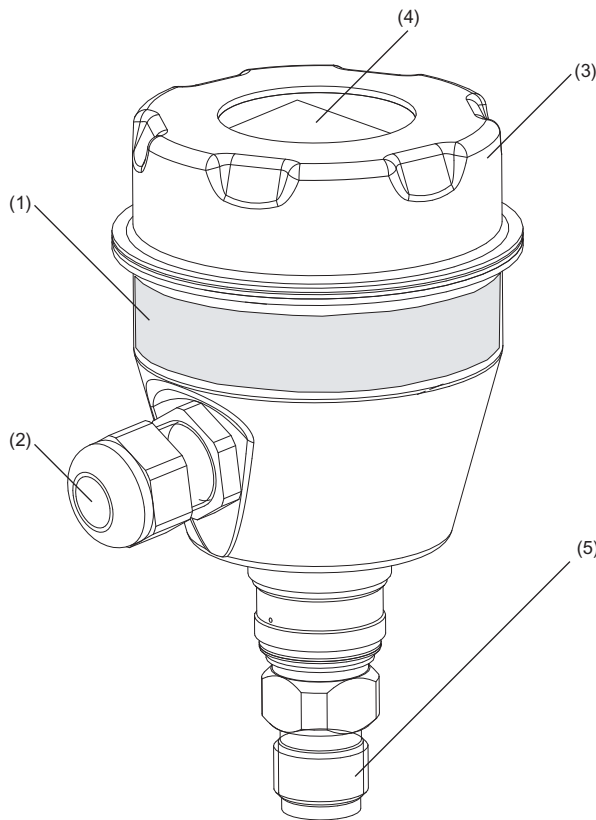

Figure 3-2 Perspective view of the P300

- | | |
|---------------------|------------------------|
| (1) Nameplate | (4) Digital display |
| (2) Cable gland | (5) Process connection |
| (3) Screwable cover | |

The housing has a screwable cover, with or without an inspection window depending on the version. The electrical cable compartment, the buttons for operation of the device and, depending on the version, the digital display are located under this cover. The connections for the auxiliary power U_H and the shield are in the cable compartment. The cable gland is on the side of the housing. The measuring cell with the process connection (5) is located on the underside of the housing. Depending on the version of the device, the measuring cell with the process connection may differ from the one shown in the diagram.

3.5 Structure of the nameplate

Overview

The nameplate which bears the order number and other important information such as design or technical details is found on the housing.

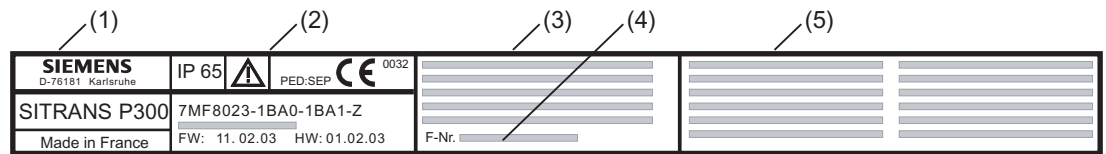

Figure 3-3 Nameplate

- | | |
|-------------------------------|-------------------------------|
| (1) Product name/manufacturer | (4) Serial number |
| (2) Product information | (5) Certification information |
| (3) Specifications | |

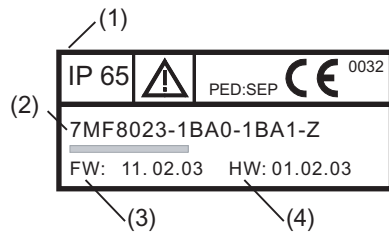

Figure 3-4 Product information

- | | |
|--------------------------|--------------|
| (1) Degree of protection | (3) Firmware |
| (2) Order no. | (4) Hardware |

3.6 Mode of operation

3.6.1 Overview of mode of operation

This chapter describes how the transmitter works.

First the electronics are described, then the physical principle of the sensors which are used with the various device versions for the individual measurement types.

3.6.2 Operation of the electronics

Description

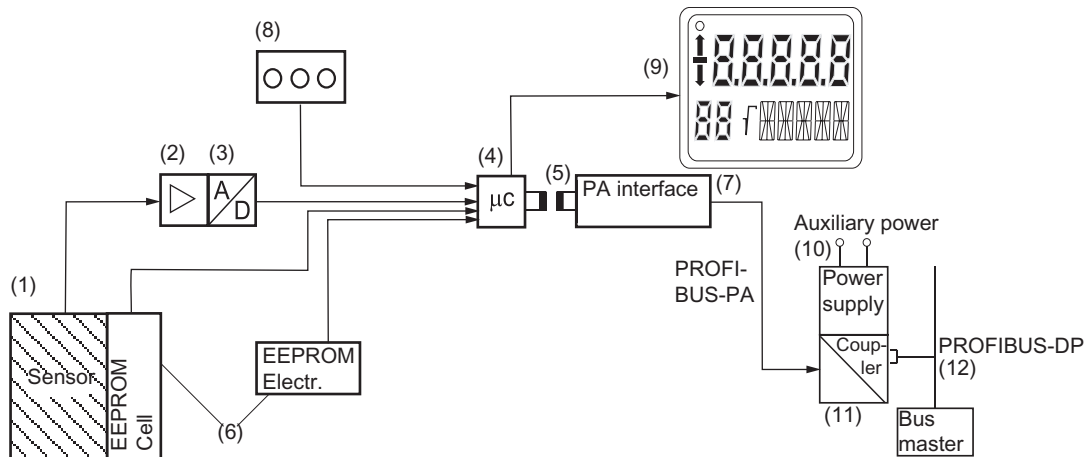

Figure 3-5 Operation of the electronics with PROFIBUS-PA communication

- (1) Measuring cell sensor
- (2) Measuring amplifier
- (3) Analog-to-digital converter
- (4) Microcontroller
- (5) Voltage isolation
- (6) Each with a non-volatile memory in the measuring cell and in the electronics
- (7) PROFIBUS-PA interface
- (8) Buttons (local operation)
- (9) Digital display
- (10) Auxiliary power source
- (11) DP/PA coupler or link
- (12) Bus master

The input pressure is converted into an electrical signal by the sensor (1). This signal is amplified by the measuring amplifier (2) and digitized in an analog to digital converter (3). The digital signal is analyzed in a microcontroller (4) and corrected with regard to linearity and thermal characteristics. It is then made available on the PROFIBUS PA via a voltage-isolated PROFIBUS-PA interface (7). The data specific to the measuring cell, the electronic data and parameter settings are stored in two non-volatile memories (6). The first memory is linked with the measuring cell, the second with the electronics.

The buttons (8) can be used to call up individual functions, so-called modes. You can track the mode settings and other device messages. The basic mode settings can be changed with a computer via the bus master (12).

Definition: Coupler

in PROFIBUS, connects the DP and PA segments. It has a fixed baud rate. The baud rate is 45.45 kbps (DP) to 31.25 kbps (PA).

Definition: Link

is a coupler with a variable baudrate. The maximum baud rate is 12 Mbps (DP) to 31.25 kbps (PA).

3.6.3 Measuring cell operation

In the following sections, the process variable to be measured is called general input pressure.

Overview

The following modes of operation are described:

- Gauge pressure
- Absolute pressure

The following process connections are available, for example:

- G $\frac{1}{2}$
- $\frac{1}{2}$ -14 NPT
- Front-flush membrane:
 - F&B and pharma flange
 - Bioconnect/Biocontrol



Caution

If the measurement signal fails because of sensor breakage, the seal diaphragm may also be destroyed.

In the worst case, the process medium escapes at the process connection in devices for gauge pressure with a span of ≤ 63 bar.

Measuring cell for gauge pressure

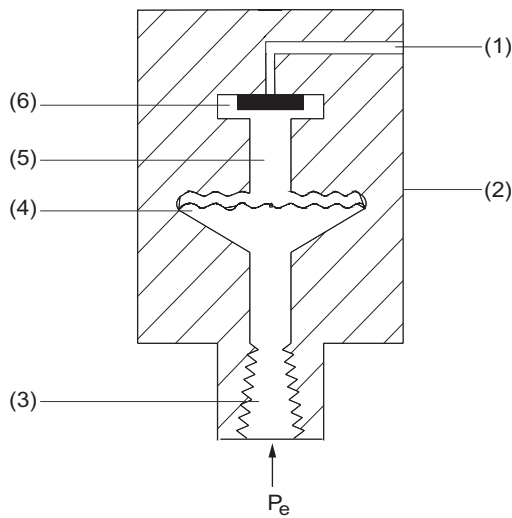

Figure 3-6 Function chart of measuring cell for gauge pressure

- (1) Reference pressure
- (2) Measuring cell
- (3) Process connection
- (4) Separating diaphragm
- (5) Fill liquid
- (6) Gauge pressure sensor
- p_e Input pressure

The input pressure (p_e) is transferred to the gauge pressure sensor (6) via the seal diaphragm (4) and the fill liquid (5), displacing its measuring diaphragm. The displacement changes the resistance value of the four piezo resistors in the measuring diaphragm in a bridge circuit. The change in the resistance causes a bridge output voltage proportional to the input pressure.

The transmitters with spans ≤ 63 bar measure the input pressure against atmosphere, those with spans ≥ 160 bar against vacuum.

Measuring cell for absolute pressure

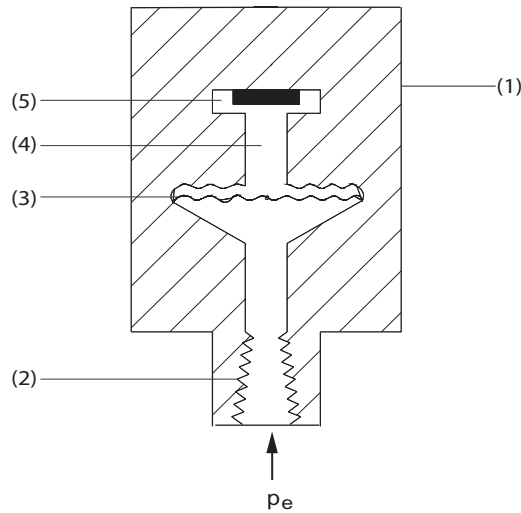

Figure 3-7 Function chart of measuring cell for absolute pressure

- (1) Measuring cell
- (2) Process connection
- (3) Separating diaphragm
- (4) Fill liquid
- (5) Absolute pressure sensor
- p_e Input pressure

The input pressure (p_e) is transferred to the absolute pressure sensor (6) via the seal diaphragm (3) and the fill liquid (4), displacing its measuring diaphragm. The displacement changes the resistance value of the four piezo resistors in the measuring diaphragm in a bridge circuit. The change in the resistance causes a bridge output voltage proportional to the input pressure.

Measuring cell for gauge pressure, front-flush membrane

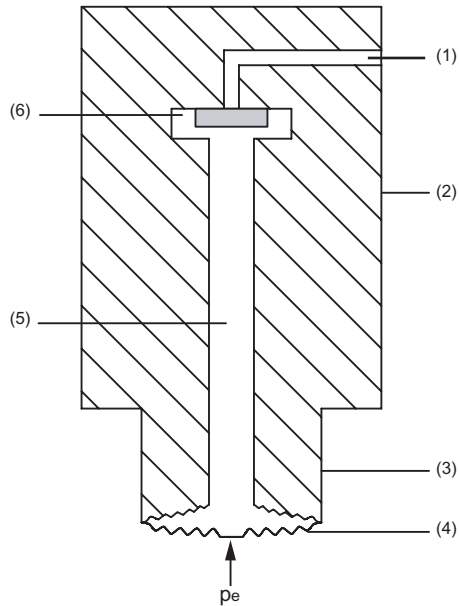

Figure 3-8 Function chart of measuring cell for gauge pressure (front-flush)

- (1) Reference pressure
- (2) Measuring cell
- (3) Process connection
- (4) Separating diaphragm
- (5) Fill liquid
- (6) Gauge pressure sensor
- p_e Input pressure

The input pressure (p_e) is transferred to the gauge pressure sensor (6) via the seal diaphragm (4) and the fill liquid (5), displacing its measuring diaphragm. The displacement changes the resistance value of the four piezo resistors in the measuring diaphragm in a bridge circuit. The change in the resistance causes a bridge output voltage proportional to the input pressure.

Transmitters with spans ≤ 63 bar measure the input pressure against atmosphere, those with spans ≥ 160 bar against vacuum.

Measuring cell for absolute pressure, front-flush membrane

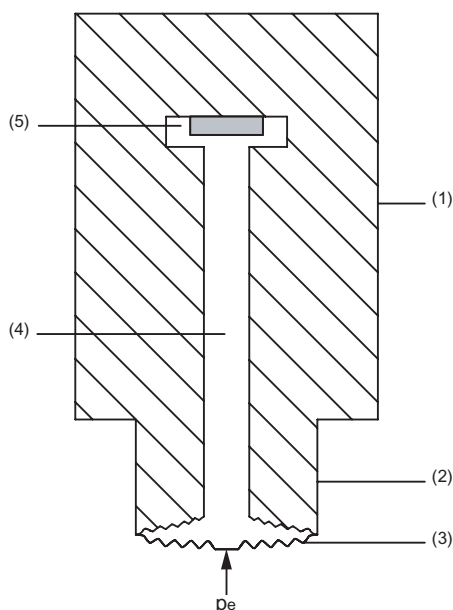

Figure 3-9 Function chart of measuring cell for absolute pressure (front-flush)

- (1) Measuring cell
- (2) Process connection
- (3) Separating diaphragm
- (4) Fill liquid
- (5) Absolute pressure sensor
- p_e Input pressure

The input pressure (p_e) is transferred to the absolute pressure sensor (6) via the seal diaphragm (3) and the fill liquid (4), displacing its measuring diaphragm. The displacement changes the resistance value of the four piezo resistors in the measuring diaphragm in a bridge circuit. The change in the resistance causes a bridge output voltage proportional to the input pressure.

3.7 SIMATIC PDM

SIMATIC PDM is a software package for the configuration, parameterization, commissioning, diagnosis, and servicing of the SITRANS P300 and other process equipment.

SIMATIC PDM includes simple process monitoring of process values, alarms, and device status information.

Using SIMATIC PDM, you can do the following with process device data:

- display
- set
- change

- compare
- check for plausibility
- administer
- simulate

3.8 PROFIBUS

3.8.1 Overview

The Process Field Bus (PROFIBUS) is an open communication system for automation technology and is specified in the European standard EN 50170.

PROFIBUS Process Automation (PROFIBUS PA) is a variant of PROFIBUS Decentral Peripherals (PROFIBUS DP), which is widely used in process technology.

3.8.2 Transmission technology

PROFIBUS PA uses a special transmission technology, enabling it to fulfill the requirements of process automation and process technology. This transmission technology is defined in the international standard IEC 61158-2. The low transmission rate reduces the power loss in comparison to PROFIBUS DP, enabling an intrinsically safe technology for use in hazardous zones with explosive atmospheres.

3.8.3 Topology

The bus topology can be largely freely selected, so that line, star, and tree structures, as well as mixed forms, are possible. All types of field devices such as sensors, actors, analysis devices, etc. can be connected to the PROFIBUS PA.

Advantages include:

- Savings on installation costs
- More extensive diagnostics, leading to increased availability of installation sections
- Automatic management of installation documentation
- Installation optimization on the fly during operation

In an automation system, there are in general multiple PROFIBUS-PA strands connected to the fast PROFIBUS DP via coupler units. This is also connected to the process control system.

Both bus systems use the same protocol layer. This makes PROFIBUS PA a "communications-compatible" extension of the PROFIBUS DP into the field.

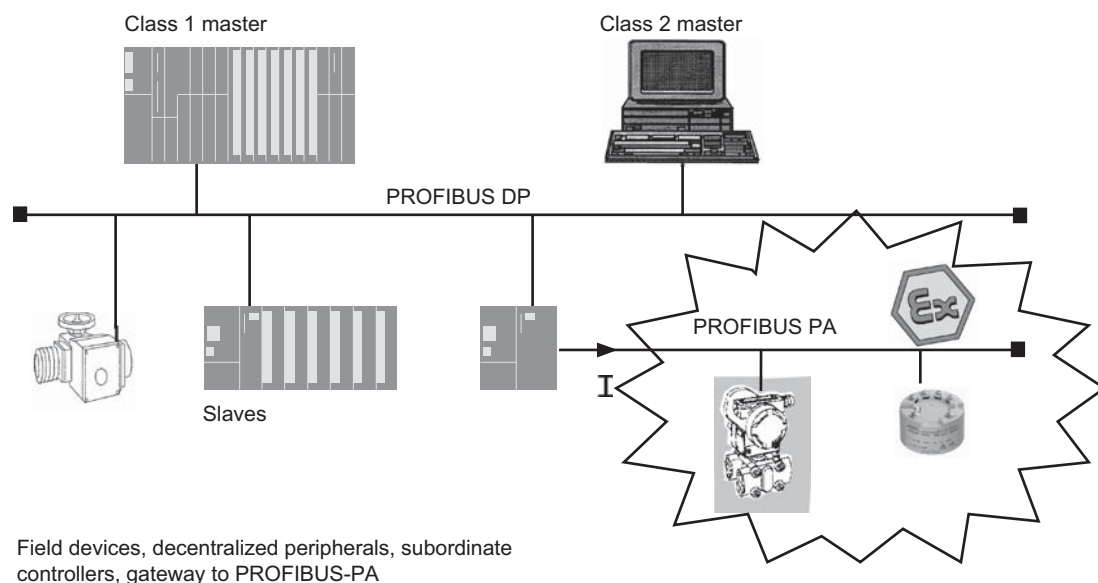

Figure 3-10 Functional principle of the PROFIBUS automation system

The figure shows a section of a typical PROFIBUS automation system. The control system consists of two masters with distributed tasks.

The class-1 master performs control and regulation tasks, while the class-2 master enables operation and observation functions. Between the class-1 master and the field devices there is a periodic exchange of measurement and settings data. The status information from the field devices is transmitted parallel to this data, and evaluated in the class-1 master. Parameterization of the field devices or the readout of additional device information is not performed during periodic operation.

Besides periodic operation, one or more class-2 masters can access the field devices asynchronously. Using this type of communication, additional information can be retrieved from the devices or settings sent to them.

Definition: Device master data

The control system finds the information necessary for establishing communications in the device master data (DMD).

Reference

http://www.ad.siemens.de/csi_e/gsd

3.8.4 Properties of PROFIBUS PA

Properties

PROFIBUS PA enables the bidirectional communication of a bus master with field devices. At the same time, the shielded two-strand wiring provides auxiliary power to the two-wire field devices.

Profile

As an extension to the EN 50170 standard, the PROFIBUS user organization (PNO) defined the functionality of the individual field device types in a so-called profile description. This profile determines minimum functional requirements and optional extensions. The device-internal "Device Management" provides the configuration tool of the control system with all necessary basic information to find profile parameters. One parameterization tool serves all profile-conforming devices, regardless of type or manufacturer.

Depending on the size of the installation (and therefore the number of field devices) and the time behavior required, you implement the system with one or more PROFIBUS PA strands. One PROFIBUS PA strand consists of the components shown in the following figure.

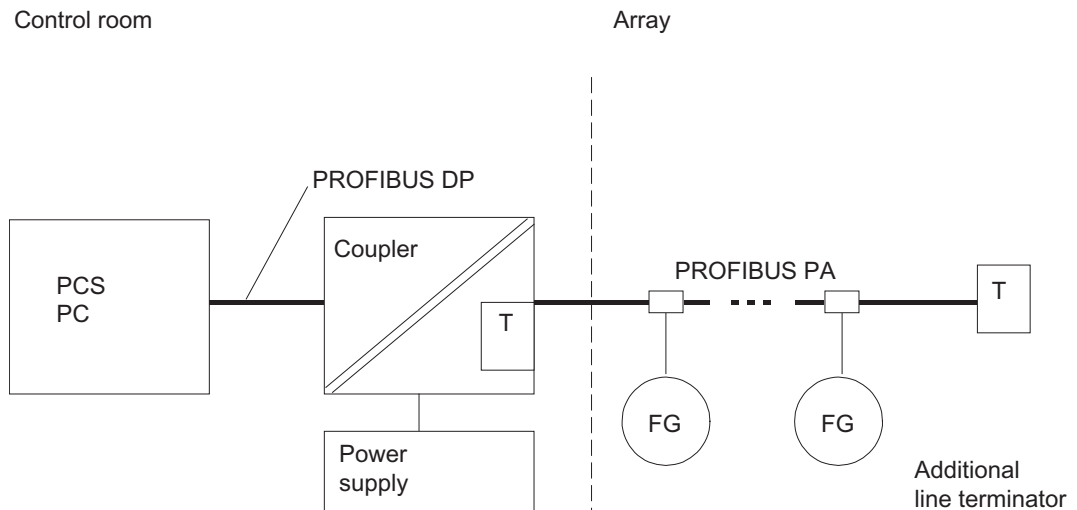

Figure 3-11 PROFIBUS PA strand

FG	Field device	PC	Personal Computer
T	Terminating resistor	PCS	Process control system

Connection

Control is performed by the central process control system (PCS), or by a PC for lower-performance requirements.

In general, the following functions are combined into one coupling assembly:

- DP/PA signal transfer

- Bus power
- Bus termination

Depending on the number of the PROFIBUS PA field devices to be operated in the automation system and the time behavior required, a DP/PA coupler or a DP/PA link is used. For standard requirements, you use a DP/PA coupler; for higher requirements, a more powerful DP/PA link.

For reasons related to transmission technology, the bus is also equipped on the far end with a terminating resistance T. When using the recommended bus cable, the theoretical maximum cable length is 1900 meters. The theoretical maximum cable length is the sum of all cable segments. During planning, also take into account the voltage drop over the wires powering the field devices.

However, the power requirements of the individual nodes and the voltage drop on the cable must also be calculated during projection. The individual field devices (FD) can be connected at nearly any point in the bus system.

DP/PA couplers or DP/PA links are supplied using a safety extra-low voltage (SELV) power supply. This power supply must have sufficient reserves to bridge over temporary power failures.

The maximum number of devices which can be connected to one bus strand depends on their power consumption and the conditions of use. When operated in the safe zone, the couplers or links supply the bus with up to 400 mA.

When operated in explosive atmospheres, intrinsic safety is only guaranteed if all devices, components, etc. connected to the bus (e.g. bus terminator) fulfill the following requirements:

- They are certified as intrinsically safe equipment.
- They fulfill the requirements of the FISCO model (Fieldbus Intrinsic Safety Concept).

Power supply devices in particular (bus couplers) must be certified as so-called FISCO power supplies. Observe the safety-relevant maximum values and other specifications of the EG type test certificate.

Connect power supplies (bus couplers) which are not explosion protected and certified to intermediate EX-certified zener barriers. Observe the specifications of the EG type test certificate.



Warning

For power supply to intrinsically safe PROFIBUS, use only power supplies, DP/PA couplers, or DP/PA links certified as compliant with the FISCO model.

Switch through zener barriers if using non-EX-protected power supplies. See the requirements of the EG type test certificate.

The number of devices which can be connected to a bus strand can be calculated from the sum of the maximum power consumption of the devices and the power available. By default, assume 10 mA per device. For safety reasons, plan for a power reserve. Otherwise you run the risk of a defective device overloading the bus with an increased power consumption. This can interrupt the power supply and communication with the functioning nodes. The amount of power reserved is based on the nominal power increase given by the manufacturer in case of failure.

Description

3.8 PROFIBUS

So that the connected process devices can be distinguished from one another, each device has its own address.

Reference

PNO PROFIBUS-PA interest group

See also

Literature and catalogs (Page A-1)

Installation

4.1 Safety information for installation

Requirement

The SITRANS P300 transmitter can be installed in different application areas.

Depending on the area of application and the system configuration, there may be differences in the installation.



Warning

Protection against incorrect use of the measuring device

Take particular care to ensure that the selected materials for the wetted parts are suitable for the process media used.

Ignoring this safety measure may cause bodily and life-threatening injury and damage the environment.



Caution

Contact protection is required for surface temperatures $> 70\text{ °C}$.

The shock protection must be designed in such a way that, if there is a buildup of heat, the maximum permitted ambient temperature at the device is not exceeded.

The permissible ambient temperature can be found in the specifications.

Caution

The device may only be used within the measuring range, overload pressure limits and voltage limits dependent on the protection type specified on the nameplate.

Notice

External loads may not be allowed to affect the transmitter as this may result in an incorrect measured value or even destruction of the device. In the worst case scenario, the process medium will escape.



Warning

"Intrinsically-safe" protection type

Information for operating the intrinsically-safe version in hazardous areas:

Operation is only permissible in certified intrinsically-safe circuits. The transmitter corresponds to category 1/2 and may be installed in Zone 0.

The EC type examination certificate applies to installation of the device in the walls of containers and pipes in which explosive gas/air or vapor/air mixtures occur only under atmospheric conditions (Pressure: 0.8 bar to 1.1 bar; Temperature: -20 °C to +60 °C). The permitted range of the ambient temperature is to be found in the specifications or, for explosion-proof devices, in the EC type examination certificate.

The operator may use the device under non-atmospheric conditions outside the limits specified in the EC type examination certificate (or the certification applicable in the country of use) at the operator's own risk if safety measures which may be necessary in accordance with use conditions (explosive mixture) have been taken. The limit values specified in the general specifications are to be complied with in all cases.

Additional information for zone 0

Additional requirements apply for installation in zone 0:

The installation must be sufficiently tight (IP67 according to EN 60 529). For instance, an industry standard (e.g. DIN, NPT) threaded connector is suitable.

When operating with intrinsically safe power supplies in category "EEX ia", explosion safety does not depend on the chemical stability of the isolation membrane.

When operating in Zone 0 with intrinsically safe power supplies in category "EEx ib", a regular leakage test must be performed to test the seal of the isolation membrane of the transmitter. Under these operating conditions, the transmitter may only be used for such combustible gases and liquids for which the seal diaphragm is sufficiently resistant to chemicals and corrosion.

4.2 Installing gauge and absolute pressure versions

4.2.1 Information for installing gauge and absolute pressure versions

Requirements

The installation location is to be as follows:

- Easily accessible
- As close as possible to the measuring point
- Vibration-free
- Within the permitted ambient temperature values

Note

Protect the transmitter against:

- Direct heat radiation
 - Rapid temperature fluctuations
 - Heavy contamination
 - Mechanical damage
-

Notice

Compare the desired operating data with the data on the nameplate.

Notice

The housing may only be opened for maintenance, local operation or to make electrical connections.

Installation configuration

The transmitter may in principle be configured above or below the pressure tapping point. The recommended configuration depends on the medium.

Installation configuration for gases

Install the transmitter above the pressure tapping point.

4.3 Installation for level version

Lay the pressure tubing with a constant gradient to the pressure tapping point, so that any condensate produced can drain in the main line and thereby avoid corruption of the measured values.

Installation configuration for vapor and liquid

Install the transmitter below the pressure tapping point.

Lay the pressure tubing with a constant gradient to the pressure tapping point so that any gas pockets can escape in the main line.

4.2.2 Installation for gauge and absolute pressure

Notice

When installing the process connection of the pressure transmitter, do not turn it on the housing.

Procedure

To install the transmitter for pressure or absolute pressure, proceed as follows:
Attach the transmitter to the process connection with an appropriate tool.

4.3 Installation for level version

4.3.1 Information for installing level version

Requirement

The installation location is to be as follows:

- Easily accessible
- As close as possible to the measuring point
- Vibration-free
- Within the permitted ambient temperature values

Note

Protect the transmitter against:

- Direct heat radiation
- Rapid temperature fluctuations
- Heavy contamination
- Mechanical damage

Notice

Compare the desired operating data with the data on the nameplate.

Notice

The housing may only be opened for maintenance, local operation or to make electrical connections.

Installation configuration

The transmitter can only be used in non-pressurized vessels for level.

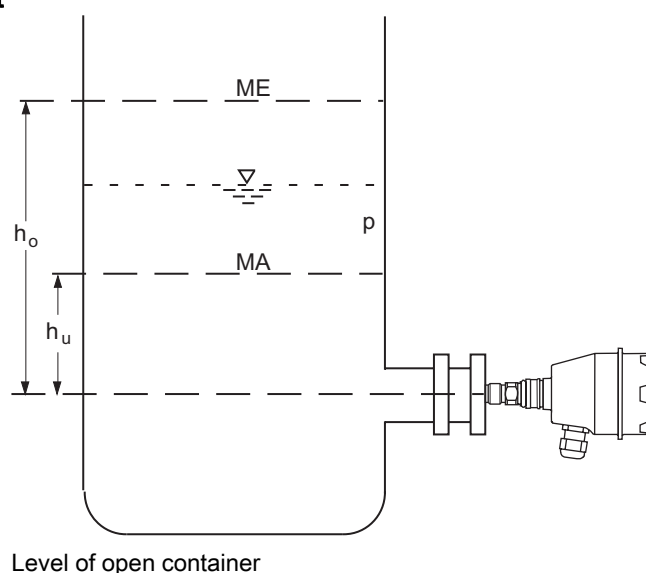
Installation height

Formula:

Zero point: $p_{MA} = \rho \cdot g \cdot H_u$

Zero point: $p_{ME} = \rho \cdot g \cdot H_o$

4.3 Installation for level version

MA	Zero point	$\Delta\rho_{MA}$	Limit point to be adjusted
ME	Limit point	$\Delta\rho_{ME}$	Limit point to be adjusted
ρ	Pressure	ρ	Density of the measured medium in the container
h_U	Zero point	g	Local gravitational acceleration
h_o	Limit point		

Note

Select the height of the container flange for recording of the transmitter (*measuring point*) such that the lowest level to be measured is always over the flange or at its upper edge.

4.3.2 Installation for level

Note

Seals are required for the installation.
Seals are not included in the delivery.

Procedure

To install the transmitter for level, proceed as follows:

1. Attach the seal to the container's mating flange.
Ensure that the seal is centrally positioned and that it does not restrict the movement of the flange's seal diaphragm in any way as otherwise the tightness of the process connection is not guaranteed.
2. Screw on the transmitter's flange.
3. Observe the installation position.

Connecting

5.1 Connection safety information

Requirement



Warning**Fixed installation**

Devices to be operated in hazardous areas should be connected with fixed cable installation. This is not necessary for intrinsically safe devices or devices with ignition protection class "nL" – "limited energy".



Warning**Tightness**

Use cable with a diameter of 7 to 12 mm for protection class IP65 through IP68.



Warning

Observe the provisions of the test certification valid for your country.

Electrical connection in hazardous areas with explosive atmospheres

The national directives and laws for hazardous areas valid in your country must be observed for electrical connection.

In Germany these are, for example:

- Operational safety regulations
- Directive for the installation of electrical systems in hazardous areas DIN EN 60079-14 (previously VDE 0165, T1)

If auxiliary power is required, check that it corresponds with that on the nameplate and with the test certification valid for your country.

Note

To improve the reliability:

- Install the signal cable separately from cables with voltages > 60 V.
 - Use cable with twisted strands.
 - Stay away from large electrical systems.
 - Use shielded cable to guarantee the full specification according to HART.
-

5.2 Connecting the transmitter

Requirement

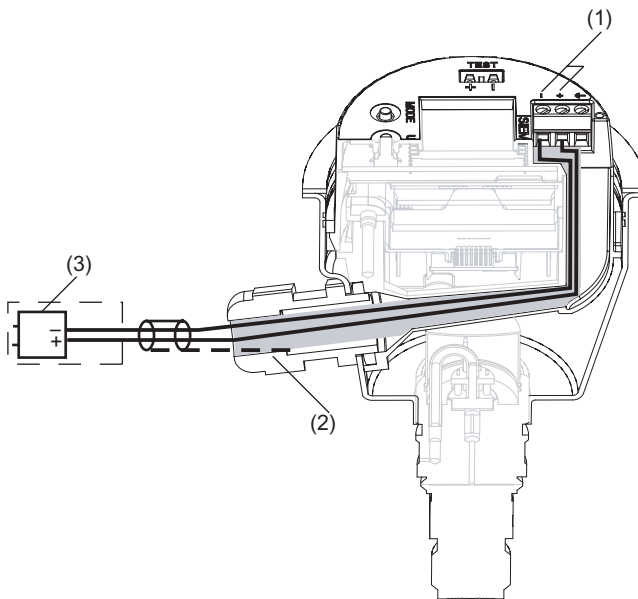

Figure 5-1 Connecting

- | | | | |
|-----|-------------------------------|-----|----------------|
| (1) | Supply terminals | (3) | Bus connection |
| (2) | Shield coating on cable gland | | |

Procedure

To connect the transmitter, proceed as follows:

1. Strip approx. 14 cm of the cable.
2. Unscrew the cover of the electrical cable compartment.
3. Insert the cable set via the cable gland through a guide channel.
The guide channel connects the cable gland with the cable compartment.
4. Connect the strands to the supply terminals (1) "+" and "-".
The device is polarity-independent.
5. Attach the shielding to the cable gland (2).
6. Screw the cover back into place.

Operation

6.1 Overview of operation

Introduction

The following description provides an overview of the operating functions which can be executed with the pressure transmitter and the safety information which is to be observed when doing so. Since the transmitter can be operated on site and via PROFIBUS, first the local operation and then the PROFIBUS operating functions will be described.

If there are references to further information on an aspect described here, these will always be found at the end of a chapter under "See also".

Overview

Contents:

- Safety information for operation
- Information on operation
- Digital display
- Local operation

Overview of operating functions

You can operate the basic settings of the pressure transmitter using the buttons on the device. The entire range of settings can be operated via PROFIBUS.

The following table describes the basic operating functions offered by a device with a digital display.

Table 6-1 Operating functions

Function	With buttons	Over PROFIBUS
Electrical damping	Yes	Yes
Zero point calibration (position correction)	Yes	Yes
Key lock and write protection	Yes	Yes
Measured value display	Yes	Yes
Unit	Yes	Yes
Bus address	Yes	Yes
Device operation type	Yes	Yes
Decimal point	Yes	Yes
Zero point drift	Yes	Yes
LO calibration	Yes	Yes
HI calibration	Yes	Yes
Customized characteristic curve	No	Yes
Diagnostics function	No	Yes
Measurement type	No	Yes

Further operating functions are accessible via PROFIBUS for special applications.

6.2 Safety information for operation

Notice

If you have set the basic functions of the pressure transmitter as user defined, the display and measurement output terminal can be adjusted such that the true process pressure is not reproduced.

The basic variables should therefore be checked prior to commissioning.

6.3 Information on operation

Introduction

The following tips apply to on-site operation of the pressure transmitter:

- The device always counts successively upward from the lowest displayed point.

If you hold the <UP> button down for a longer period, it counts to the next highest displayed point. This process allows for a rough adjustment over a wide range. For fine adjustment, use the <UP> or <DOWN> button again. Press the button again.

Violations of the measured value limits are displayed on the digital display with ↑ or ↓.

- To operate the device locally, the key lock must be released.
- The readout of data is always possible locally or also over PROFIBUS.
- If write protection is deactivated, changing the data is possible locally as well as over the PROFIBUS.

Note

If more than 2 minutes has passed since the last key was pressed, the setting is automatically saved and the device automatically returns to the measured value display.

6.4 Digital display

6.4.1 Elements of the digital display

Structure

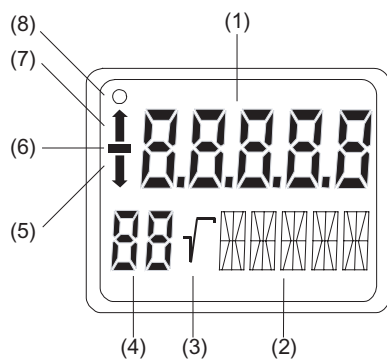

Figure 6-1 Structure of the digital display

- | | |
|----------------------|-------------------------------|
| (1) Measured value | (5) Violation of lower limit |
| (2) Unit/error code | (6) Symbol for measured value |
| (3) Root display | (7) Violation of higher limit |
| (4) Mode/button lock | (8) Communication display |

Description

The digital display is used for the local display of the measured value (1) with:

- Unit (2)
- Mode (4)
- Symbol (6)
- Status (5) and (7)

The measured value display (1) presents the measurement in a selectable physical unit according to the customer settings.

The displays Violation of lower limit (5) and Violation of upper limit (7) are also referred to as statuses as they have meanings dependent on the settings.

The communications display (8) shows that communication with the PROFIBUS is active.

6.4.2 Units display

Description

The unit display consists of five 14-segment fields for displaying the unit as a percentage value or physical unit.

Display

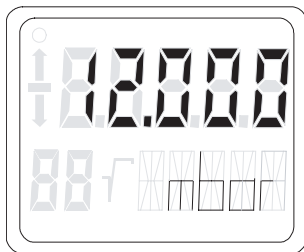

Figure 6-2 Example for measured pressure value display

6.4.3 Error display

Description

If hardware faults, software errors or diagnostic alarms occur in the transmitter, the message "Error" appears in the measured value display.

A status code appears in the lower line of the digital display indicating the type of error. This diagnostic information is also available via PROFIBUS.

Error messages are displayed for about 10 seconds after the occurrence of the error.

Display

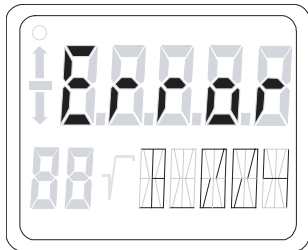

Figure 6-3 Example of error message

See also

Overview of status codes (Page A-2)

6.4.4 Mode display

Description

The selected active mode is shown in the mode display.

Display

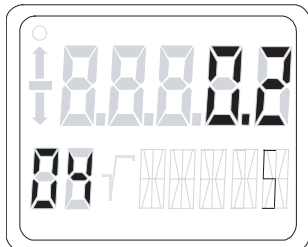

Figure 6-4 Example for mode display

In the example, a damping of 0.2 seconds was set in mode 4.

6.4.5 Status display

Description

The arrows of the status display have a different meaning depending on the mode setting. The table below shows the meanings of the arrows in the respective functions.

Meaning

Table 6-2 Meaning of the arrow displays

Function	Mode	Display↑	Display↓
Measured value display		Pressure exceeds the upper sensor limit.	Pressure falls below the lower sensor limit.
Adjusting damping	4	Exceeds of the upper damping value	Exceeds of the lower damping value
LO calibration	19	–	Calibration span too low
HI calibration	20	Calibration span too high	–
Alarm		Upper alarm limit reached	Lower alarm limit reached
Warning		Upper warning limit reached	Lower warning limit reached

See also

Overview of status codes (Page A-2)

6.5 Local operation

6.5.1 Local control elements

Introduction

The transmitter can be operated on site with the keys (buttons). Selectable modes can be used to choose and execute the functions described in the table.

Control elements

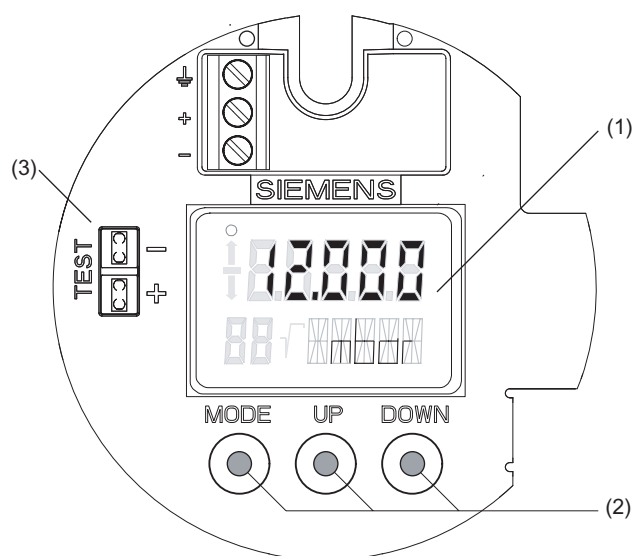

Figure 6-5 Position of keys and digital display

- (1) Digital display
(2) Keys
(3) Test connector

Operating functions

Table 6-3 Operating functions via keys

Function	Mode	Key function			Display, explanations	
	<MODE>	<UP>	<DOWN>	<UP> and <DOWN>		
Measured value	The modes are selected here.				The current measured value is displayed as you have adjusted it in the "Measured value display, mode 13" function.	
Electrical damping	4	Damping higher	Damping lower		Time constant T_{63} in seconds Adjustment range: 0.0 s to 100.0 s	
Zero point calibration (position correction)	7			Execute	Pressurizing transmitter for gauge pressure or level Transmitter for absolute pressure: Mode deactivated. Measured value in pressure unit	
Key lock or function lock	10	Change	Change	-	--	None
		Save			L	Write protection Operation via PROFIBUS not possible.

Function	Mode	Key function			Display, explanations
	<MODE>	<UP>	<DOWN>	<UP> and <DOWN>	
Source of measured value display	13	Select from various options.		–	Selection of different variables
Unit	14	Select from the table for measured values display.		In each case the first value from the table of the physical unit	Physical unit
Bus address	15	Larger	Smaller		Address on PROFIBUS Value between 0 and 126
Device operation type	16	Select	Select		Select device operating type
Decimal point	17	To the right	To the left		Position of decimal point
Zero point adjustment	18				Display of current measurement range
LO calibration	19	Preset larger	Preset smaller	Execute	Calibrate lower point on characteristic
HI calibration	20	Preset larger	Preset smaller	Execute	Calibrate upper point on characteristic

Definition: Zero point adjustment

After the following functions, the measurement range is changed:

- Zero-point calibration (mode 7)
- LO calibration (mode 19)
- HI calibration (mode 20)

If you have executed one of these functions, the measurement range has changed. This changed, remaining measurement range is called the zero-point adjustment. The value displayed by the device in mode 18 is a positive pressure.

6.5.2 Operating via keys

Introduction

This overview provides you with most important safety information required to operate the pressure transmitter. The overview also instructs you how to adjust the operating functions on site.

Requirement



Warning
Intrinsically safe circuits

With intrinsically-safe circuits, use only certified power supplies or couplers appropriate for the transmitter.



Warning
Specific type examination certificates

Observe the provisions of the EG type test certification or the local test certification valid for your country.

Note

The housing should be cleaned to prevent dirt and moisture entering the device.

To operate the device via the keys, the key lock must be released.

Procedure

The device is set to measured value display by default.

To adjust the operating functions, proceed as follows:

1. Unscrew the cover.
2. Press the <MODE> key until the desired mode is displayed.
3. Press the <UP> or <DOWN> key until the desired value is displayed.
4. Press the <MODE> key.
This saves the values and the device then jumps to the next mode.
5. Screw the cover back into place.

Note

If more than 2 minutes has passed since the last key was pressed, the setting is automatically saved and the device automatically returns to the measured value display.

6.5.3 Adjusting electrical damping

Introduction

In mode 4, set the electrical damping. The time constants of the electrical damping can be set between 0 and 100 seconds in 0.1 second steps using the buttons. This electrical damping also acts as the device's own basic damping.

Requirement

You are familiar with the correct operation of the transmitter and the associated safety information.

The basic calibration of the steps is a 0.1 second interval. The longer you depress the <UP> and <DOWN> key, the greater the steps.

Procedure

To adjust the electrical damping, proceed as follows:

1. Set mode 4.
2. Adjust the desired damping.
3. Save with the <Mode> key.

Result

Electrical damping has been adjusted to the desired time constant.

The electrical damping only has an effect on the output of the analog input function block.

See also

Electrical damping (Page 7-17)

Operating via keys (Page 6-8)

6.5.4 Zero point calibration

Introduction

The zero point is calibrated in mode 7. Zero point calibration corrects zero point errors resulting from the installation position of the pressure transmitter. The device type determines the way in which you proceed.

SIMATIC PDM shows you the sum of all zero-point corrections.

Correct this offset in the following boundaries:

Gauge pressure	-100 %, but not more than -1 bar, up to +100 % of the nominal measurement range
Absolute pressure	Mode 7 blocked

Requirement

You are familiar with the correct operation of the transmitter and the associated safety information.

Zero point calibration for gauge pressure transmitter

To calibrate the zero point, proceed as follows:

1. Pressurize the transmitter.
2. Set mode 7.
3. Press the <UP> and <DOWN> keys simultaneously for 2 seconds.
4. Save with the <Mode> key.

Result

The value 0 is displayed in the digital display, with the appropriate number of decimal points depending on:

- Nominal measurement range
- Pressure unit selected

See also

Operating via keys (Page 6-8)

6.5.5 Locking keys

Introduction

Functions which can generally be carried out via the keys can be locked in mode 10. Application examples for a lock include backup of the saved parameters.

Lock options

You have the following lock options on the pressure transmitter:

Table 6-4 Meaning of the lock modes

Lock mode	Meaning
--	The device can be operated by means of the keys and PROFIBUS communication.
L	Write protection Operation via the keys and PROFIBUS communication is locked. Exception: <ul style="list-style-type: none">• Releasing key lock

Requirement

You are familiar with the correct operation of the transmitter and the associated safety information.

Note

Check the measured value display function to see whether the desired setting is displayed.

Procedure

To lock the keys, proceed as follows:

1. Set mode 10.
2. Select the desired lock mode.
3. Confirm the lock mode by pressing <MODE>.

See also

- Operating via keys (Page 6-8)
- Releasing key or function lock (Page 6-12)
- Key lock and write protection (Page 7-17)

6.5.6 Releasing key or function lock

Procedure

To release write protection for PROFIBUS (L) using the keys, proceed as follows:

1. Set mode 10.
2. Press the <UP> and <DOWN> keys simultaneously for 5 seconds.

6.5.7 Source of measured value display

Introduction

In mode 13, select a variable which represents the source of the measured value display. The variable is based on the measurement type set at the factory or through the bus. The measurement type cannot be set locally.

The measurement type options available can be set in SIMATIC PDM using the "transmitter type" parameter. Find the following values under this parameter:

- Pressure
- Flow, not relevant for gauge and absolute pressure
- Level
- Volume

Requirement

You are familiar with the correct operation of the transmitter and the associated safety information.

Procedure

To select the source for the measured value display, proceed as follows:

1. Set mode 13.
2. Select the variable.
3. Save with the <Mode> key.

Parameter

The following tables give the meaning of the variables, depending on the value of the "transmitter type" parameter. This allows you to select the units available in mode 14.

Table 6-5 Measurement type "Pressure"

Source of measured value display	Variable	Available unit	
From analog input function block:			
[0] : Output :	OUT	(P) (U)	Pressure User specific
From pressure transducer block:			
[1] : Secondary variable 1	SEC 1	(P)	Pressure
[2] : Measurement value (primary variable)	PRIM	(P)	Pressure
[3] : Sensor temperature	TMP S	(T)	Temperature
[4] : Electronics temperature	TMP E	(T)	Temperature

Source of measured value display	Variable	Available unit	
[5] : Secondary variable 3:	SEC 3	(M)	Mass / mass flow Flow not relevant for gauge and absolute pressure
[7] : Raw pressure value	SENS	(P)	Pressure
From totalizer function block:			
[6] : Totalizer output	TOTAL	(V) (ΣM) *)	Volume Total mass flow Flow not relevant for gauge and absolute pressure

Table 6-6 Measurement type "Level"

Source of measured value display	Variable	Available unit	
From analog input block:			
[0] : Output	OUT	(L) (U)	Level User specific
From pressure transducer block:			
[1] : Secondary variable 1	SEC 1	(P)	Pressure
[2] : Measurement value (primary variable)	PRIM	(L)	Level
[3] : Sensor temperature	TMP S	(T)	Temperature
[4] : Electronics temperature	TMP E	(T)	Temperature
[5] : Secondary variable 3:	SEC 3	(M)	Mass / mass flow Flow not relevant for gauge and absolute pressure
[7] : Raw pressure value	SENS	(P)	Pressure
From totalizer function block:			
[6] : Totalizer output	TOTAL	(V) (ΣM) *)	Volume Total mass flow Flow not relevant for gauge and absolute pressure

*) The option of selecting the physical unit is additionally determined by the channel setting (mass or volume) of the analog input and totalizer function blocks.

Table 6-7 Measurement type "Volume"

Source of measured value display	Variable	Available units	
From analog input block:			
[0] : Output	OUT	(V) (U)	Volume User specific
From pressure transducer block:			
[1] : Secondary variable 1	SEC 1	(P)	Pressure
[2] : Measurement value (primary variable)	PRIM	(V)	Volume
[3] : Sensor temperature	TMP S	(T)	Temperature

Source of measured value display	Variable	Available units	
[4] : Electronics temperature	TMP E	(T)	Temperature
[5] : Secondary variable 3:	SEC 3	(M)	Mass / mass flow Flow not relevant for gauge and absolute pressure
[7] : Raw pressure value	SENS	(P)	Pressure
From totalizer function block:			
[6] : Totalizer output	TOTAL	(V) (ΣM) *)	Volume Total mass flow Flow not relevant for gauge and absolute pressure

*) The option of selecting the physical unit is additionally determined by the channel setting (mass or volume) of the analog input and totalizer function blocks.

See also

Block model for collection and processing of measured values (Page 7-1)

Pressure transducer block (transducer block 1) (Page 7-4)

Operating via keys (Page 6-8)

6.5.8 Unit

Introduction

In mode 14, set the physical unit in which the device's measured value display should be represented.

Requirement

You are familiar with the correct operation of the transmitter and the associated safety information.

You have already selected the desired source for the measured value display in mode 13.

Procedure

To adjust the physical unit, proceed as follows:

1. Set mode 14.

The physical unit used appears in the lower line of the digital display.

2. Select a unit.
3. Save with the <Mode> key.

The following tables show the physical units available in each measurement type.

Units

Table 6-8 Unit for pressure (P)

Unit	Identifier	Display
Pa	1130	Pa
MPa	1132	MPa
kPa	1133	KPa
hPa	1136	hPa
bar	1137	bar
mbar	1138	mbar
torr	1139	Torr
atm	1140	ATM
psi	1141	PSI
g/cm ²	1144	G/cm2
kg/cm ²	1145	KGcm2
inH2O	1146	INH2O
inH2O(4°C)	1147	INH2O
mmH2O	1149	mmH2O
mmH2O(4°C)	1150	mmH2O
ftH2O	1152	FTH2O
inHg	1155	IN HG
mmHg	1157	mm HG

Table 6-9 Unit for volume (V)

Unit	Identifier	Display
m3	1034	m3
dm3	1035	dm3
cm3	1036	cm3
mm3	1037	mm3
l	1038	L
cl	1039	cL
ml	1040	mL
hl	1041	hL
in3	1042	IN3
ft3	1043	FT3
yd3	1044	Yd3
pint (US)	1046	Pint
quart (US)	1047	Quart
US gallon	1048	GAL
imp. gallon	1049	ImGAL
bushel	1050	BUSHL

Unit	Identifier	Display
barrel	1051	bbl
barrel liquid	1052	bblli

Table 6-10 Unit for level (L)

Unit	Identifier	Display
m	1010	m
cm	1012	cm
mm	1013	mm
ft	1018	FT
in	1019	IN
yd	1020	Yd

Table 6-11 Unit for mass (M)

Unit	Identifier	Display
kg	1088	KG
g	1089	G
t	1092	T
oz	1093	oz
lb	1094	lb
STon	1095	STon
LTon	1096	LTon

Table 6-12 Unit for temperature (T)

Unit	Identifier	Display
K	1000	K
°C	1001	°C
°F	1002	°F
°R	1003	°R

Table 6-13 Unit for user-specific (U)

Unit	Identifier	Display
arbitrary	1995	Max. 16 characters, If more than 5 characters, the digital display shows the unit as a ticker. The input of the characters to be displayed can only be performed through the PROFIBUS.
%	1342	%

Note

The profile allows a much larger number of possible units. There is no limitation on some physical values special to the output of the analog input function block. For instance, if you have selected a unit with SIMATIC PDM which does not appear in the corresponding valid list, the current measurement value will be shown without a unit in the measured value display.

See also

Units of the pressure transducer block (Page 7-8)

Operating via keys (Page 6-8)

6.5.9 Bus address

Introduction

The node address of the device on the PROFIBUS, the so-called bus address, is set in mode 15. The permissible range runs from 0 to 126.

Requirement

You are familiar with the correct operation of the transmitter and the associated safety information.

Note

Do not change the bus address of the device while your system is running. The device will then no longer be visible from the application program.

Procedure

To change the bus address, proceed as follows:

1. Set mode 15.
The currently set bus address of the device appears in the measured value display.
2. Select the bus address within the permissible range.
3. Save with the <Mode> key.

See also

Operating via keys (Page 6-8)

6.5.10 Device operation type

Introduction

Set the device operation type in mode 16.

The device operation type [1] is preset on the pressure transmitter. Other device operation types are only suitable if you have set another operation type through PROFIBUS.

Table 6-14 Device operation type

Display	Meaning
[0]	Profile-compatible: Exchangeable for transmitters with PROFIBUS PA Profile 3.0, with analog input function block, without totalizer
[1]	Delivery state Profile-compatible with extensions: Full functionality of the SITRANS P300 with: <ul style="list-style-type: none"> • Analog input function block • Totalizer
[2]	Not relevant
[128]	Profile-compatible: Exchangeable for transmitter with PROFIBUS PA Profile 3.0 with: <ul style="list-style-type: none"> • Analog input function block • Totalizer.

Requirement

You are familiar with the correct operation of the transmitter and the associated safety information.

Procedure

To change the device operation type, proceed as follows:

1. Set mode 16.
The current operation type appears in the measured value display.
2. Select the device operation type.
The local operation type must match the operation type in PROFIBUS.
3. Save with the <Mode> key.

Note

Each device operation type is assigned a particular device master data file (GSD file).

If the configuration of your PROFIBUS-PA strand does not correspond to the device operation type selected, the device will not start periodic data exchange. Successful establishment of communications can be seen by the communications indicator "o" in the upper left of the digital display.

Note

If the device is exchanging period data, no change is possible to the device operating type.

Table 6-15 Device master data file

Display	File name
	"?" stands for the GSD version.
[0]	pa_?9700.gsd
[1]	siem8121.gsd
[2]	sip1804B.gsd
[128]	pa_?9740.gsd

See also

Errors (Page 10-1)

Operating via keys (Page 6-8)

6.5.11 Position of the decimal point

Introduction

Set the position of the decimal point in mode 17. Measured values can be displayed by the device with up to four decimal places.

Requirement

You are familiar with the correct operation of the transmitter and the associated safety information.

Procedure

To move the decimal point, proceed as follows:

1. Set mode 17.

A mask appears in the digital display showing the current position of the decimal point.

2. Select the desired display format.

8.8888

88.888

888.88

8888.8

88888

3. Save with the <Mode> key.

Note

If you set the decimal point too far to the right, the resolution of the display may be too low. The digital display may show, for instance, "0" instead of "0.43".

If you set the decimal point too far to the left, it can overflow. Then the digital display will show the character sequence 9.9.9.9 and error code F_004 instead of the measured value.

See also

Operating via keys (Page 6-8)

Errors (Page 10-1)

6.5.12 Display of the zero-point adjustment

Introduction

The zero-point adjustment is shown in mode 18.

Requirement

You are familiar with the correct operation of the transmitter and the associated safety information.

Procedure

To display the current zero-point adjustment, proceed as follows:

1. Set mode 18.

The current zero-point adjustment appears in the digital display.

2. Close with the <Mode> key.

See also

Operating via keys (Page 6-8)

6.5.13 LO calibration

Introduction

The slope of the characteristic is changed in mode 19. This rotates the characteristic around setting point HI.

This function replaces the zero-point calibration (mode 7) which is not permitted for absolute pressure transmitters.

The unit in which you want to calibrate is set using the following functions:

- In mode 13, set the source of the measured value display[7] : Raw pressure value, variable SENS.
- In mode 14, select the desired pressure unit.

Note

If you change this setting, the measurement range can be restricted to the point that the permissible sensor limits are violated even with small pressure changes.

Requirement

You are familiar with the correct operation of the transmitter and the associated safety information.

Procedure

In order to calibrate an LO, proceed as follows:

1. Set mode 19.
The digital display shows the value of the last calibration procedure, with the appropriate unit.
2. Create the reference pressure.
3. Press the <UP> or <DOWN> key.
The measured value display switches to the current pressure value. Using the <UP> and <DOWN> keys, you can enter the reference value starting from there.
4. Press the <UP> and <DOWN> keys simultaneously for 2 seconds.
5. Save with the <Mode> key.

Result

If the calibration was successful, the current measurement value of the device will be displayed, and will correspond to the calibration value as long as the reference pressure is still applied.

If you switch to the measured value display without taking a sufficiently large calibration span into account, the pressure status "Bad" B_004 will be displayed.

The shutdown logic of the function block is activated and the output shows the status "Unsure" U_0xx, depending on the configuration.

If the two calibration points are too close together, status F_006 is displayed. The smallest calibration span depends on the nominal measurement range. Select either the higher reference pressure in mode 20, or the lower reference pressure in mode 19.

As long as mode 19 is active, you can repeat this procedure as often as necessary.

View LO calibration

To view the LO calibration, proceed as follows:

1. Set mode 19.
The digital display shows the value of the last calibration procedure, with the appropriate unit.
2. Leave the mode by pressing <MODE>.

See also

Calibrating the sensor (Page 7-26)

Errors (Page 10-1)

Operating via keys (Page 6-8)

6.5.14 HI calibration

Introduction

The slope of the characteristic is changed in mode 20. This rotates the characteristic around setting point LO.

The unit in which you want to calibrate is set using the following functions:

- In mode 13, set the source of the measured value display[7] : Raw pressure value, variable SENS.
- In mode 14, select the desired pressure unit.

Note

If you change this setting, the measurement range can be restricted to the point that the permissible sensor limits are violated even with small pressure changes.

Procedure

To calibrate HI, proceed as follows:

1. Set mode 20.

The digital display shows the value of the last calibration procedure, with the appropriate unit.

2. Create the reference pressure.

3. Press the <UP> or <DOWN> key.

The measured value display switches to the current pressure value. Using the <UP> and <DOWN> keys, you can enter the reference value starting from there.

4. Press the <UP> and <DOWN> keys simultaneously for 2 seconds.

5. Save with the <Mode> key.

Result

If the calibration was successful, the current measurement value of the device will be displayed, and will correspond to the calibration value as long as the reference pressure is still applied.

If you switch to the measured value display without taking a sufficiently large calibration span into account, the pressure status "Bad" B_004 will be displayed.

The shutdown logic of the function block is activated and the output shows the status "Unsure" U_0xx, depending on the configuration.

If the two calibration points are too close together, status F_006 is displayed. The smallest calibration span depends on the nominal measurement range. Select either the higher reference pressure in mode 20, or the lower reference pressure in mode 19.

As long as mode 20 is active, you can repeat this procedure as often as necessary.

Viewing the HI calibration

To view the HI calibration, proceed as follows:

1. Set mode 20.

The digital display shows the value of the last calibration procedure, with the appropriate unit.

2. Leave the mode by pressing <MODE>.

See also

Calibrating the sensor (Page 7-26)

Errors (Page 10-1)

Operating via keys (Page 6-8)

Operating functions over PROFIBUS

7.1 Communication structure for PROFIBUS PA

7.1.1 Overview

This chapter describes the processing method of the device-specific function blocks using a graphical block model which is resolved into its individual layers step by step. Knowledge of the physical block is assumed: It will thus not be explained in this chapter.

Definition: Function block

A named block consisting of one or more inputs, outputs, and included parameters.

Function blocks represent the basic automation functions executed by an application in a way as independent as possible from the details of I/O devices and the network. Each function block processes input parameters using a specified algorithm and a set of internally stored parameters. They produce output parameters which are available for use inside the same function block application or by other function block applications.

7.1.2 Block model for collection and processing of measured values

The device functions are subdivided into blocks of different task areas. They can be parameterized during asynchronous data transmission.

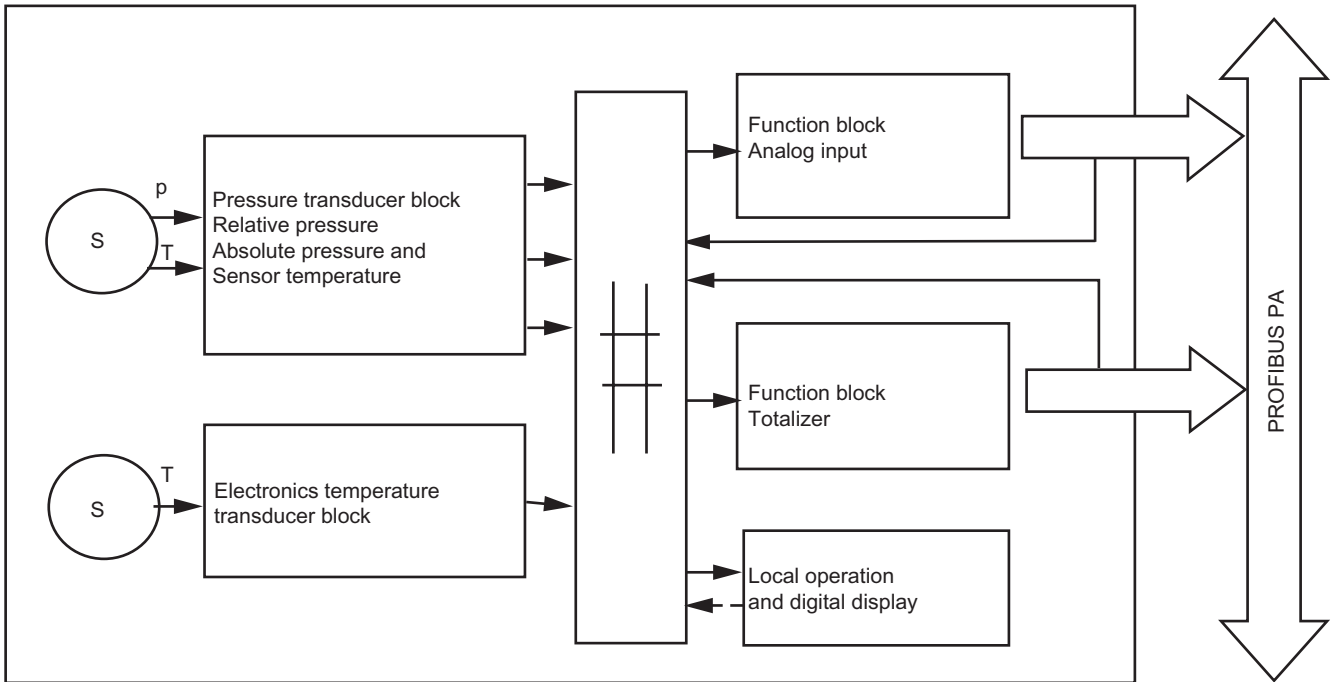

Figure 7-1 Block circuit diagram of collection and processing of measured values

p	Pressure	S	Sensor
T	Temperature		

Pressure transducer block

When measuring levels, the necessary conversions of the measurement value are performed in the pressure transducer block. The output value is the linearized and temperature-compensated measurement result.

The pressure transducer block also processes the temperature measurement of the pressure sensor and monitors the pressure and temperature limits.

Example

In hydrostatic level measurement, the pressure transducer block converts the incoming pressure value into height or volume.

Electronic temperature transducer block

The electronics temperature transducer block executes the required temperature measurement functions and monitors the permissible temperature limits.

Analog input function block

The analog input function block further processes the selected measurement value and passes it on to the automation task.

Example

For a container full of water, you measure the volume. The analog input function block calculates the container volume [m³] in a user-specific volume unit [bottles]. The output of this block gives the measured value and the corresponding status on the PROFIBUS.

Totalizer function block

The totalizer function block is not relevant for gauge or absolute pressure.

Local operation and digital display

The digital display represents the desired measured value with its physical unit. You can select different functions for local operation.

Connection between blocks via parameters

The output values of the transducer blocks for pressure and electronics temperature can be fed to the analog input and totalizer function blocks as input values for further processing. To do this, the parameter "Channel" must be correctly set in each function block.

Table 7-1 Connection between blocks

Transducer block	Output value (Parameters)	Usable in the analog input function block
Pressure	Temperature	X
	Secondary variable 1	X
	Secondary variable 2	X
	Measurement value (primary variable)	X
	Secondary variable 3	X
Electronics temperature	Electronics temperature	X

Parameters for measured value display

The values of the following parameters from the measurement and function blocks can be shown on the digital display. The parameter "Source for display" must be set appropriately.

Table 7-2 Display on digital display

Block	Parameter	On digital display displayable
Pressure transducer block	Temperature	X
	Secondary variable 1	X
	Secondary variable 2	
	Measurement value (primary variable)	X
	Secondary variable 3	X
	Raw pressure value	X
Electronics temperature transducer block	Electronics temperature	X
Analog input function block	Output	X
Totalizer function block	Totalizer output	X

See also

- Cyclical data transfer (Page 8-1)
- Acyclic data transfer (Page 8-6)
- Source of measured value display (Page 6-13)

7.1.3 Pressure transducer block

7.1.3.1 Pressure transducer block (transducer block 1)

The following figure shows the signal flow of measurement values from the sensor cell through the pressure transducer block into the appropriate output values, e.g. temperature, measurement value (primary variable), etc. The parameters of the individual functions, e.g. measurement range, output range, etc. can be changed using acyclic access.

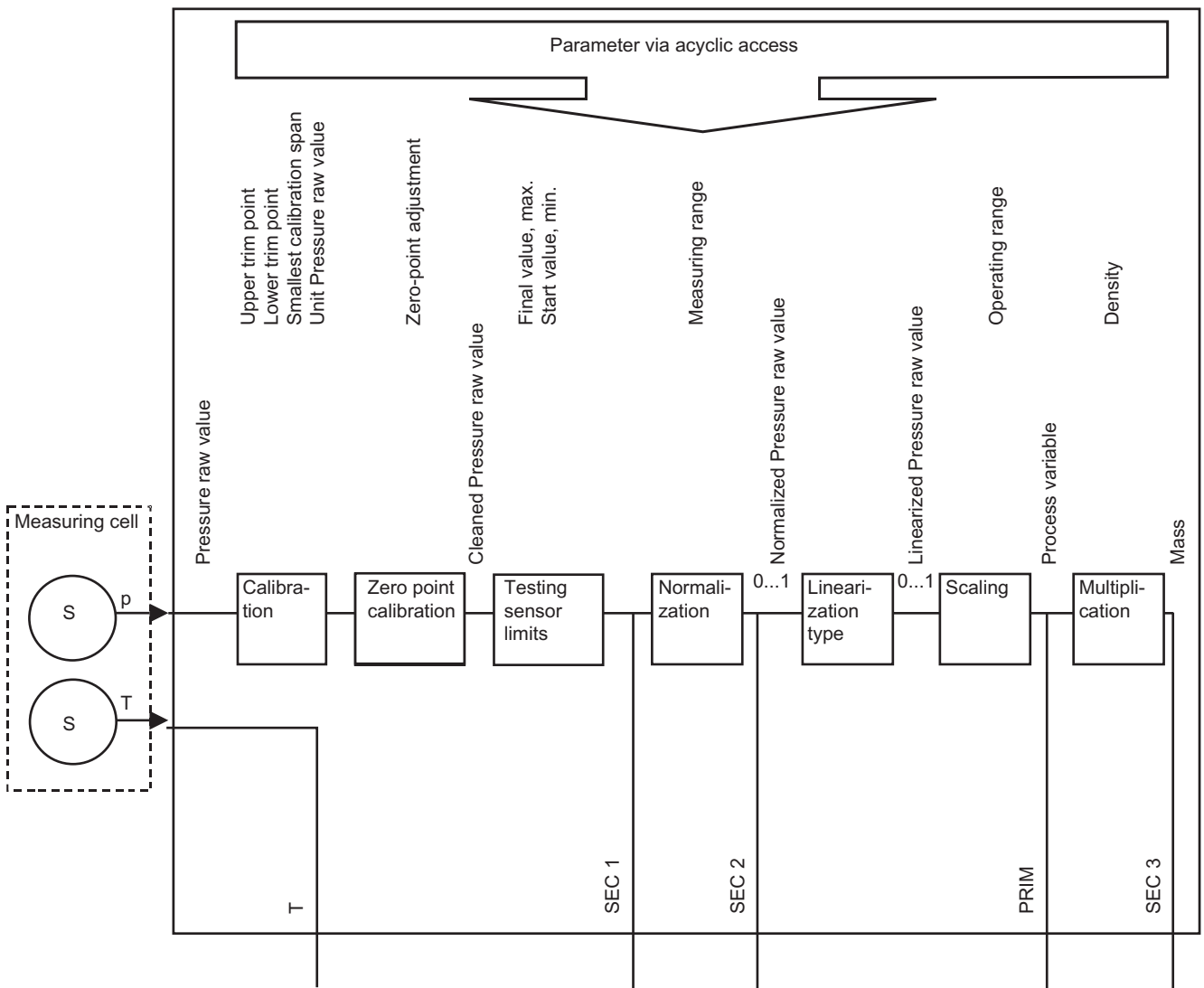

Figure 7-2 Function groups of the pressure transducer block

p	Pressure	SEC 1	Secondary variable 1
S	Sensor	SEC 2	Secondary variable 2
T	Temperature	PRIM	Primary variable
		SEC 3	Secondary variable 3

Functional principle

The **raw pressure value** first passes through a **calibration**. The resulting **cleaned-up pressure value** is checked for **sensor limits**. Any violation of the limits results in status "Bad" and a diagnostic error of "error collecting measured value". The cleaned-up pressure value is stored in **SEC 1**.

Then, it is subjected to a **normalization**, where the input signal is expressed in the range 0 to 10 (percentage/100). The **normalized pressure value** is stored in **SEC 2**.

Afterwards, depending on the measurement task, it is fed through one of four different **linearization types**. **Scaling** uses the preset **working range** (minimum and maximum values) to determine the normalized and linearized measured value (pressure, height, or volume) of the actual process variable. This is stored in **PRIM**.

By means of a **multiplication** with the **density** the volume is used to compute the **mass**. This is stored in **SEC 3**.

The **temperature value of the pressure sensor** is available in the "**temperature**" parameter.

See also

Acyclic data transfer (Page 8-6)

7.1.3.2 Linearization type function group

The normalized pressure is fed through the linearization algorithms for adjustment to the various process requirements, as shown in the following figure. The algorithm is switched using the "Characteristic type" parameter.

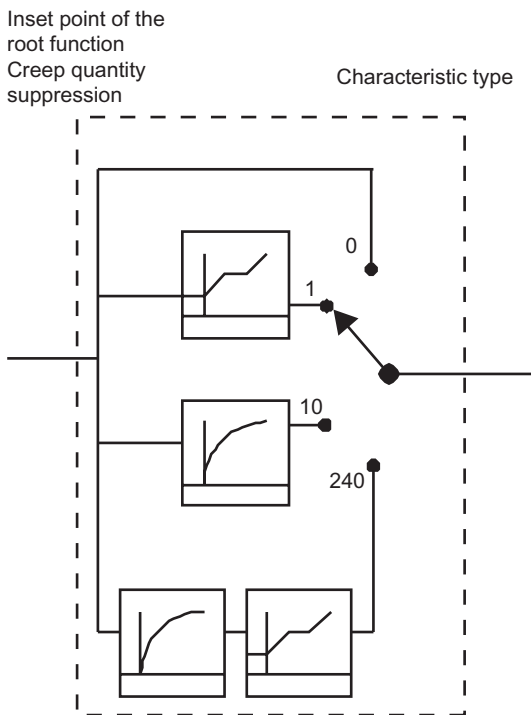
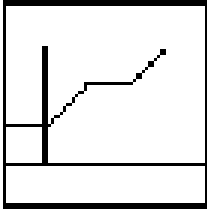

Figure 7-3 Linearization type function group

0	Linear	1	User-defined "table"
10	Root, not relevant for gauge and absolute pressure	240	Root/table, not relevant for gauge and absolute pressure

Table 7-3 Available linearization functions

Measurement task	Linearization symbol	Characteristic type	Description
Pressure measurement	-	Linear	No linearization
Level: Height	-	Linear	No linearization
Level: Volume		User defined (table)	Linearization of container characteristics. The relationship between level and volume is described using a maximum of 31 set points at arbitrary intervals.

To input a characteristic curve, select the characteristic type "user-defined (table)". Enter the "New number of set points" which you will later want to enter.

The set points must always be entered in pairs. For each point $x[n]$ in the working range, a point $y[n]$ is required.

The device checks which pair of set points bracket the pressure (secondary variable 1) gauge to the measurement range. To convert the pressure to the measured value (primary variable), the device interpolates on a line between the set points.

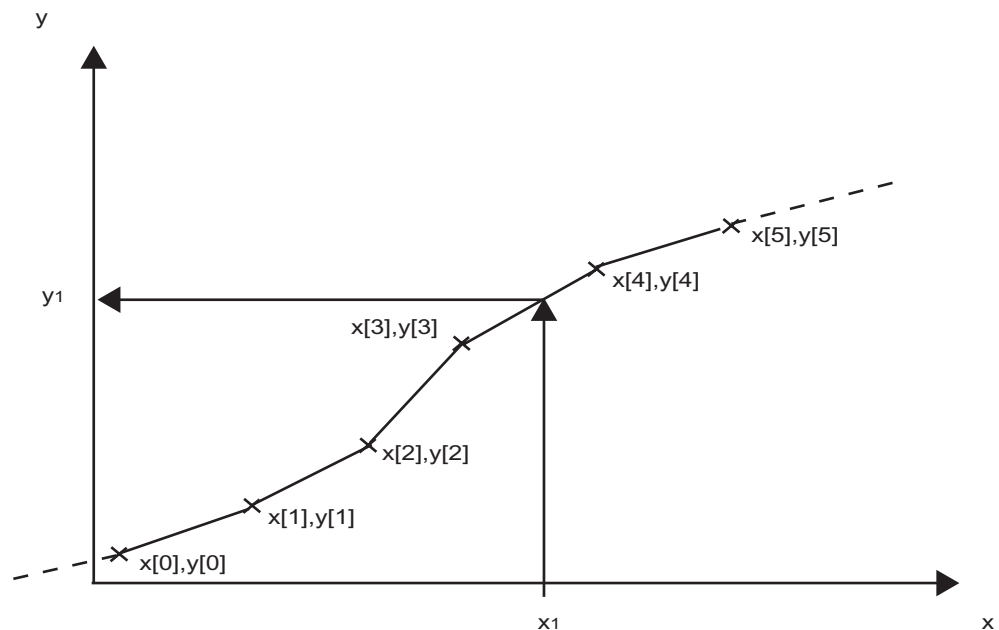

Figure 7-4 Entry of a user-defined characteristic using set points $x(i)$, $y(i)$

- x Measurement range, here e.g. pressure (secondary variable 1)
- y Working range, here e.g. volume, measured value (primary variable)

7.1.3.3 Units of the pressure transducer block

In the pressure transducer block you have the option of setting units in four different places. Depending on the measurement type, units are allowed from the following measurement functions:

Table 7-4 Overview of available units

Variable	Measurement type		
	Pressure	Level	Volume
Raw pressure value	P	P	P
Secondary variable 1	P	P	P
Measurement value (primary variable)	P	L	V
Secondary variable 3	---	---	---

P Pressure

L Level

V Volume

For the measurement values (primary variables) you can also set the unit "%" for all measurement types.

Secondary variable 2 is a value normalized to one in all measurement types. The unit is fixed at "none".

See also

Unit (Page 6-15)

7.1.4 Electronics temperature transducer block

The electronics temperature transducer block is manufacturer-specific and not described in the profile. It has the task of monitoring the internal temperature of the device electronics and cannot change the pressure value, only its status.

The permissible limits correspond to those of the permissible ambient temperature. If a limit is violated, the status changes to "GOOD – Active Critical Alarm – High/Low-limit". The status of the cleaned-up pressure value in the pressure transducer block receives the status "UNCERTAIN – Value not accurate – high/low-limit". This procedure is accompanied by a PROFIBUS diagnostic message "Electronics temperature too high".

There are also peak indicators for maximum and minimum values available.

See also

- Min/max pointer (Page 7-22)
- Status (Page 8-4)

7.1.5 Analog input function block

The analog input function block is part of the standard functions of transmitters. The following figure shows the processing of the measured values up to the **output**.

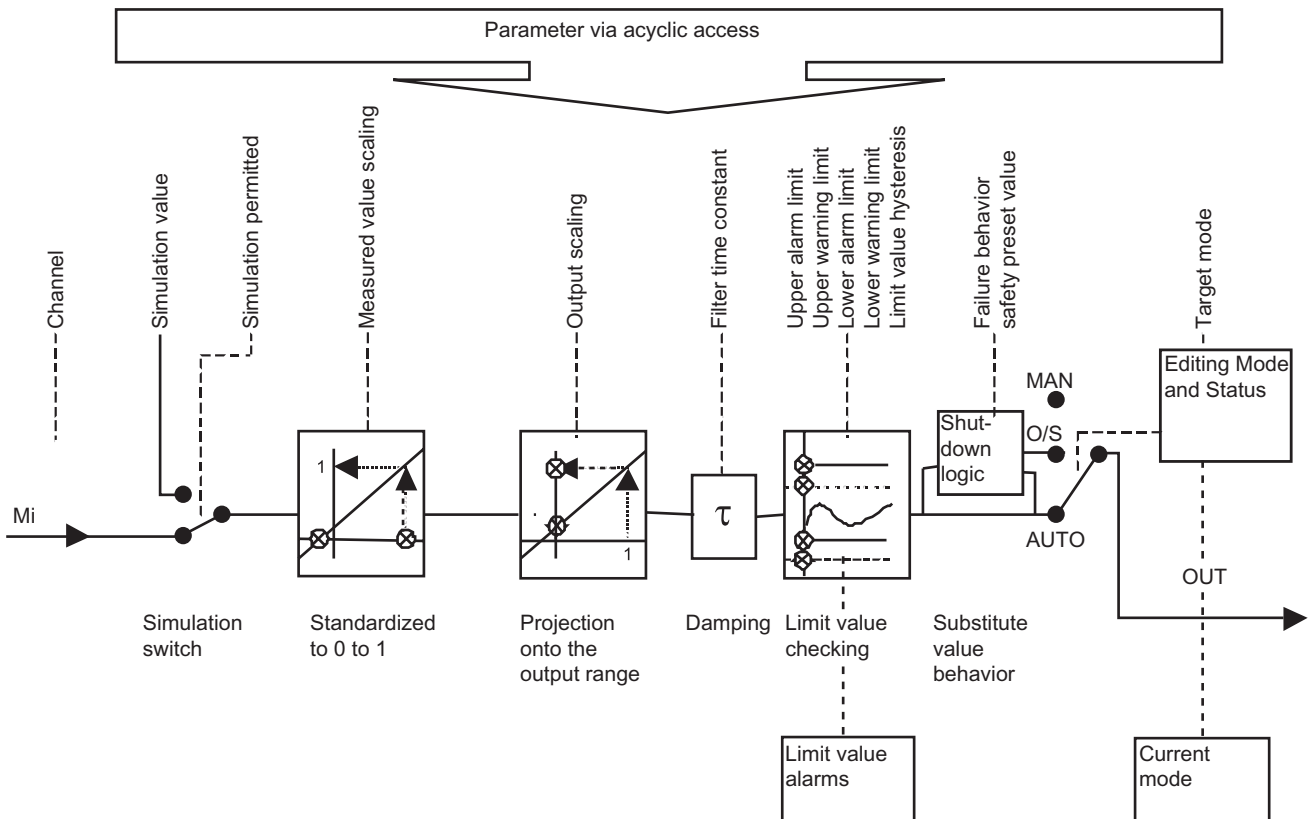

Figure 7-5 Function groups of the analog input function block

M_i	Incoming measured value from the pressure transducer block	MAN	Manual
OUT	Output (value, status)	O/S	Out of Service
		AUTO	Automatic

Functional principle

The **incoming measurement value from the pressure transducer block** - or a **simulated value** prescribed through the **simulation switch** - is subject to another **normalization** (measured value scaling) and a **projection onto the output range** through output scaling (application-specific measured value).

Afterwards, the signal is **filtered** (damping) and check for being within preset **limit values**. There is always an **upper and lower warning and alarm limit** available.

If the measured value has the status "Bad", the **shutdown logic** may output a **safety preset value**: This may be the last usable measured value or a preset substitute value.

Using the **target mode** selected in the **mode and status editor** you can choose between output of the automatically collected measured value (AUTO setting) or a manually preset simulation value (MAN setting). If the function block is out of order (O/S setting) then the safety preset is always output.

The analog input function block handles the numerical value separately from the physical unit. You can set about 100 predefined units.

See also

Unit (Page 6-15)

7.1.6 Totalizer function block

The totalizer function block belongs to the standard functions of pressure transmitters. It is used in flow measurement.

The totalizer function block is not relevant for gauge or absolute pressure.

See also

Unit (Page 6-15)

Configuration of user data (Page 8-2)

7.2 Overview of operating functions

A PC software program like SIMATIC PDM is necessary for operation over PROFIBUS PA. The operation can be seen in the corresponding user manual and the online help. The full functionality of the pressure transmitter is available via PROFIBUS PA communication.

7.3 Measurement

In measurement operation, measurement values like pressure or fill level are provided on the PROFIBUS-PA interface. PROFIBUS PA communication is signalled by the communication symbol [o] on the digital display.

See also

Elements of the digital display (Page 6-3)

7.4 Settings

7.4.1 Overview of settings

The SITRANS P300 can handle a great number of measurement tasks. You only have to make the following settings:

- Settings with a configuration tool, e.g. STEP 7 or HW config: Here, you choose the desired configuration of the cyclically transmitted data.
- Settings with SIMATIC PDM: Here you set the parameters, which can also influence the cyclical data.

See also

Configuration of user data (Page 8-2)

7.4.2 Settings

When setting up a new device, select the measurement type - e.g. pressure or fill level - and you will see the corresponding preset parameters in the SIMATIC PDM interface. The following sections will introduce only those which you will still have to set.

Procedure

To read out the settings, proceed as follows:

1. Select the action "Load into PG/PC" and read the current settings out of the device.
2. Check the current settings.
3. Change the necessary settings.
4. Load the parameter settings into the device.
5. Save the parameter settings offline.

7.4.3 Pressure measurement

Procedure

To select pressure measurement, proceed as follows:

1. Selection the target configuration "Output".
2. Create a device with the desired measurement type.
3. Start SIMATIC PDM.

No special parameter settings are necessary.

7.4.4 Fill level measurement

Procedure

To configure fill level measurement, proceed as follows:

1. Selection the target configuration "Output".
2. Create a device with measurement type "Fill level".

Depending on whether you want to measure a height, a volume, or a mass, set the following values.

Height measurement

To select height measurement, proceed as follows:

- Start SIMATIC PDM and create an assignment between the pressure to be measured (measurement range) and the fill level to be recorded (working range), by setting these parameters:

```
> Input
> > Transducer Block 1
    Transmitter type: Level
> > > Measuring
        range
        Start value
        Final value
> > > Working range
        Unit:          Unit of length [m, cm, mm, ft, in, yd]
        Start value
        Final value
```

- Create an assignment between the fill level measured value and the output value by setting these parameters:

```
> Output
> > Function Block 1 - Analog Input
    Channel: Measurement value (primary variable)
> > > Measured value scaling
        Start value:   as in "working range"
        Final value:   as in "working range"
> > > Output scaling
        Unit:          as in "working range"
        Start value:   as in "working range"
        Final value:   as in "working range"
```

You can also adjust the output to another process value. Under the heading Output scaling, assign the parameter the desired unit and the start and final values corresponding to the measurement value scaling.

Volume measurement

- Start SIMATIC PDM and create an assignment between the pressure to be measured (measurement range) and the volume to be recorded (working range), by setting these parameters:

```

> Input
> > Transducer Block 1
      Transmitter type:  Volume
> > > Measuring
        range
        Start value
        Final value
> > > Working range
        Unit:             Unit of volume [m³, dm³, cm³, mm³, l...]
        Start value
        Final value
    
```

- If there is no linear relationship between fill level and volume in your container, you can also determine a characteristic curve:

```

> Input
> > Transducer Block 1
      Transmitter type:  Volume
> > > Characteristic
        curve
        Characteristic   User-defined table
        type:
> > > Set points
        New number of set  max. 31
        points:
        x[n] measurement   Pressure value
        range:
        y[n] working range: corresponding volume value
    
```

- Create an assignment between the measured volume value and the output value by setting these parameters:

```

> Output
> > Function Block 1 - Analog Input
      Channel:  Measurement value (primary variable)
> > > Measured value scaling
        Start value:      as in "working range"
        Final value:      as in "working range"
> > > Output scaling
        Unit:             as in "working range"
        Start value:      as in "working range"
        Final value:      as in "working range"
    
```

You can also adjust the output to another process value. Under the heading Output scaling, assign the parameter the desired unit and the start and final values corresponding to the measurement value scaling.

Mass measurement

- Start SIMATIC PDM and create an assignment between the pressure to be measured (measurement range) and the volume to be recorded (working range), by setting these parameters:

```
> Input
> > Transducer Block 1
    Transmitter type: Volume
> > > Measuring
        range
        Start value
        Final value
> > > Working range
        Unit: Unit of volume [m³, dm³, cm³, mm³, l...]
        Start value
        Final value
```

- If there is no linear relationship between fill level and volume in your container, you can also determine a characteristic curve:

```
> Input
> > Transducer Block 1
    Transmitter type: Volume
> > > Characteristic
        curve
        Characteristic User-defined table
        type:
> > > Set points
        New number of set max. 31
        points:
        x[n] measurement Pressure value
        range:
        y[n] working range: corresponding volume value
```

- Create an assignment between the measured mass value and the output value by setting these parameters:
 - > Output
 - > > Function Block 1 - Analog Input
 - Channel: Measurement value (primary variable)
 - > > > Measured value scaling
 - Start value: as in "working range"
 - Final value: as in "working range"
 - > > > Output scaling
 - Unit: Unit of mass [kg, g, t ...]
 - Start value: as "measured value scaling" * density
 - Final value: as "measured value scaling" * density

You can also adjust the output to another process value. Under the heading Output scaling, assign the parameter the desired unit and the start and final values corresponding to the measurement value scaling.

See also

Adjusting to a desired process value (Page 7-15)

7.4.5 Flow measurement

Flow measurement is not relevant for gauge or absolute pressure.

7.4.6 Adjusting to a desired process value

The analog input function block has the purpose of mapping the measured value to the process value. In general, you want to direct the measured value straight to the bus: Then the input and output range is taken from the working range. If the measured pressure or the fill level has an indirect but linear relation to the process value, however, assign the start and final values of the input range to start and final values for the output range, as described in the following examples:

Procedure

The **procedure** is shown by means of two concrete application examples.

Example 1

You want to assign the input range 1 to 4 Pa to the output range 0 to 100%.

1. • Set measurement type "Pressure".
2. • Set the following parameters:
 - > Pressure transducer block
 - Unit for measured value Pa
 - (primary variable):
 - > Analog input function block
 - Input starting value: 1,0
 - Input final value: 4,0
 - Output starting value: 0,0
 - Output final value: 100,0
 - Unit (output): %

Note

The digital display can only show a part of the ASCII character set and cannot display all ASCII characters in both upper and lower case. If you enter lower-case letters f, g, j, p, q, t, x, y, z in SIMATIC PDM in the parameter "Unit text (output)", they can only be shown in upper case. The German letters ä, ö, ü, and ß, as well as any ASCII characters with codes larger than 125, are displayed with a block symbol with all segments on. Thus try to avoid language-specific characters.

Example 2

Sie möchten den Eingangsbereich 0 bis 400 m³ in 200-l-Fässer umrechnen. The output range, for instance, is 0 to 2000 barrels.

1. • Set measurement type "Volume".
2. • Set the following parameters:
 - > Pressure transducer block
 - Unit for measured value m³
 - (primary variable):
 - > Analog input function block
 - Input starting value: 0,0
 - Input final value: 400,0
 - Output starting value: 0,0
 - Output final value: 2000,0
 - Unit (output): Text
 - Unit text (output): Barrels

See also

Pressure measurement (Page 7-11)

Fill level measurement (Page 7-12)

7.5 Electrical damping

You can set the time constant of electrical damping to a point within a range from 0 to 100 seconds. It always applies to the "Pressure" device variable (DV0) and thus to the measured values derived from it.

See also

Adjusting electrical damping (Page 6-10)

7.6 Key lock and write protection

You can set operation blocks according to the following table.

Table 7-5 Keypad locks

Lock	Effect	Switching on/off	Digital display
Keypad and function block (hardward write protection)	Parameter changes with SIMATIC PDM and setting changes made locally are blocked. Independent of other operating locks.	Local Mode 10	L
Write block	Password protection for parameter changes over the bus. Local operation is possible.	SIMATIC PDM	LC
Local operation	If local operation is not released, no access is possible using the keypad. Independent of the setting of this parameter, local operation is automatically released 30 seconds after interruption of communications. After communication is restored, the "Local operation permitted" parameter is restored to its original setting in the device.	SIMATIC PDM	LA
Combination of write block and no release of local operation	Acts like an active keypad block. Changes to parameters (except for keypad block) are not possible either with local operation or using SIMATIC PDM.	SIMATIC PDM	LL

7.7 Warning and alarm limits

Blocks can also be combined:

Table 7-6 Combined blocks

Lock	Write block for parameter changes over the bus.	Release of local operation over SIMATIC PDM	Digital display
On	On or off	Released or blocked	L
Off	Off	Blocked	LA
Off	Off	Released	--
Off	On	Blocked	LL
Off	On	Released	LC

See also

Locking keys (Page 6-11)

7.7 Warning and alarm limits

The analog input function blocks each have upper and lower warning and alarm limits for the output. In order to avoid unstable display of warnings and alarms, specify a hysteresis.

In the analog input function blocks, set the following parameters according to process requirements:

- Limit value hysteresis
- Upper warning limit
- Upper alarm limit
- Lower warning limit
- Lower alarm limit

Status

If limits are violated, the output is accompanied by a status which you can evaluate in your application program:

Table 7-7 Limits and status displays

Status Digital display	Status Hex	Violation of
G_137	89	Lower warning limit
G_138	8A	Upper warning limit
G_141	8D	Lower alarm limit
G_142	8E	Upper alarm limit

Example

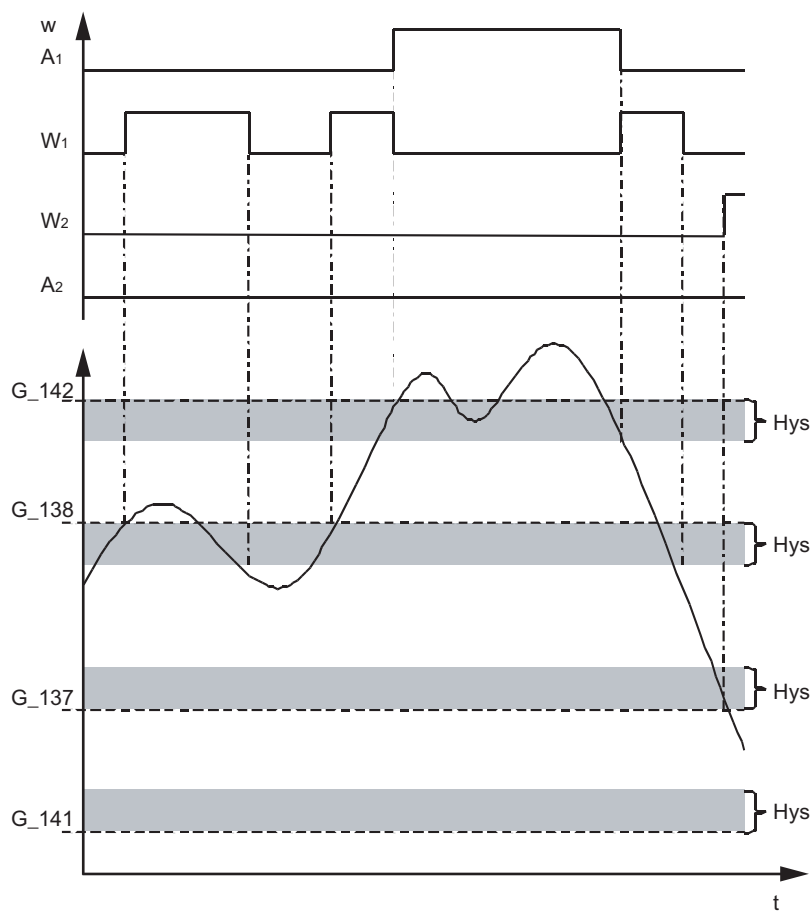

Figure 7-6 Warning and alarm limits

G_137	Lower warning limit	A ₁	Upper alarm
G_138	Upper warning limit	A ₂	Lower alarm
G_141	Lower alarm limit	W ₁	Upper warning limit
G_142	Upper alarm limit	W ₂	Lower warning limit
t	Time	Hys	Hysteresis
		w	Measured value

7.8 Failure behavior

7.8.1 Overview of failure behavior

The analog input function block can take on a behavior you define, if the transducer block should fail. If an error causes the status "Bad" to accompany the output variables of the transducer block, the function blocks activate the failure behavior. Then a status "Unsure" accompanies the output.

7.8.2 Output

Set the failure behavior in the analog input function block:

Table 7-8 Failure behavior of the analog input function block

Failure behavior	Description	Status code
The output value is set to the replacement value.	The predefined safety preset value is output.	U_075
Saving of the last valid output value.	The last valid output value is output.	U_071
The incorrectly calculated measured value is on the output (shutdown logic turned off).	The bad output value is accompanied by the status assigned to it by the transducer block.	B_0xx

To narrow down the cause of failure after the shutdown logic engages, read the measured value (primary variables) or secondary variables including the status from SIMATIC PDM.

7.9 Diagnostic functions

7.9.1 Operating hours counter

You can read out one operating hours counter for the electronics and one for the sensor. They are activated upon first commissioning of the transmitter.

7.9.2 Calibration interval and service interval

There are two timers in the SITRANS P300:

- A timer for the calibration interval, which ensures regular calibration of the electronics.
- A timer for the service interval, which draws attention to any necessary service for the sensor cell and its connections.

The interval is selectable. The timers can monitor on two levels, first giving a warning, then an alarm.

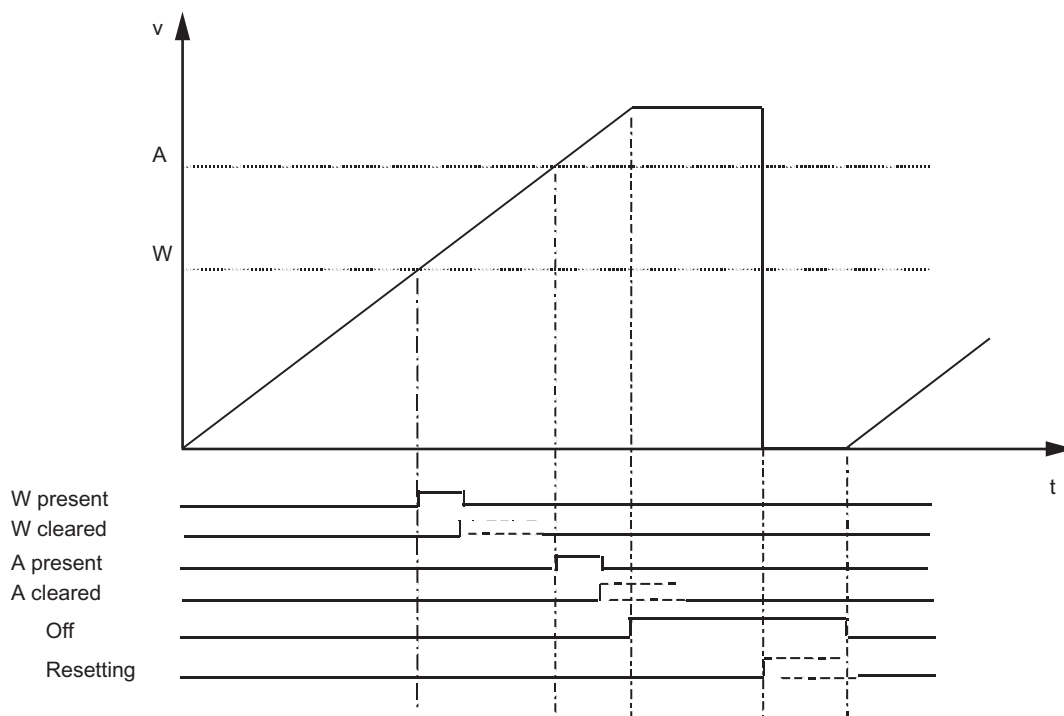

Figure 7-7 Calibration and service intervals

v	Timer value	t	Time
A	Alarm	W	Warning

Procedure

To adjust the calibration and service interval, proceed as follows:

1. Set the parameter for warning/alarm.
2. Give the time interval after which a warning is output.
3. Give the additional time interval after which an alarm is output.

7.9.3 Clearing warning

As soon as the warning interval is past, the first monitoring level emits a warning. Measured values are accompanied by the status "Good, service required" and the diagnostic message "Service required" is displayed. SIMATIC PDM can also display the status for calibration or service and the value of the timer.

Procedure

To clear a warning, proceed as follows:

1. Clear the warning.

The diagnostic message is deleted and the status set back to "Good".

2. Perform the calibration or service.
3. Reset the timer.

7.9.4 Clearing the alarm

If you don't perform calibration or service on time, the second monitoring level emits an alarm which again draws attention to the urgent need for service. Measured values are accompanied by the status "Unsure, value inexact" and the diagnostic message "Service required" is displayed.

Procedure

To clear an alarm, proceed as follows:

1. Clear the alarm.

The diagnostic message is deleted and the status set back to "Good".

2. Perform the calibration or service.
3. Reset the timer.

7.9.5 Min/max pointer

Description

The transmitter provides three min/max pointer pairs, which you can use to monitor the three measured variables Pressure, Sensor temperature, and Electronics temperature for negative and positive peak values. For each measured value, a resettable min/max pointer saves the maximum and minimum peak values in long-term storage in the two non-volatile memories. Consequently, the values are available even after the device is restarted. The min/max pointers are also updated during a simulation.

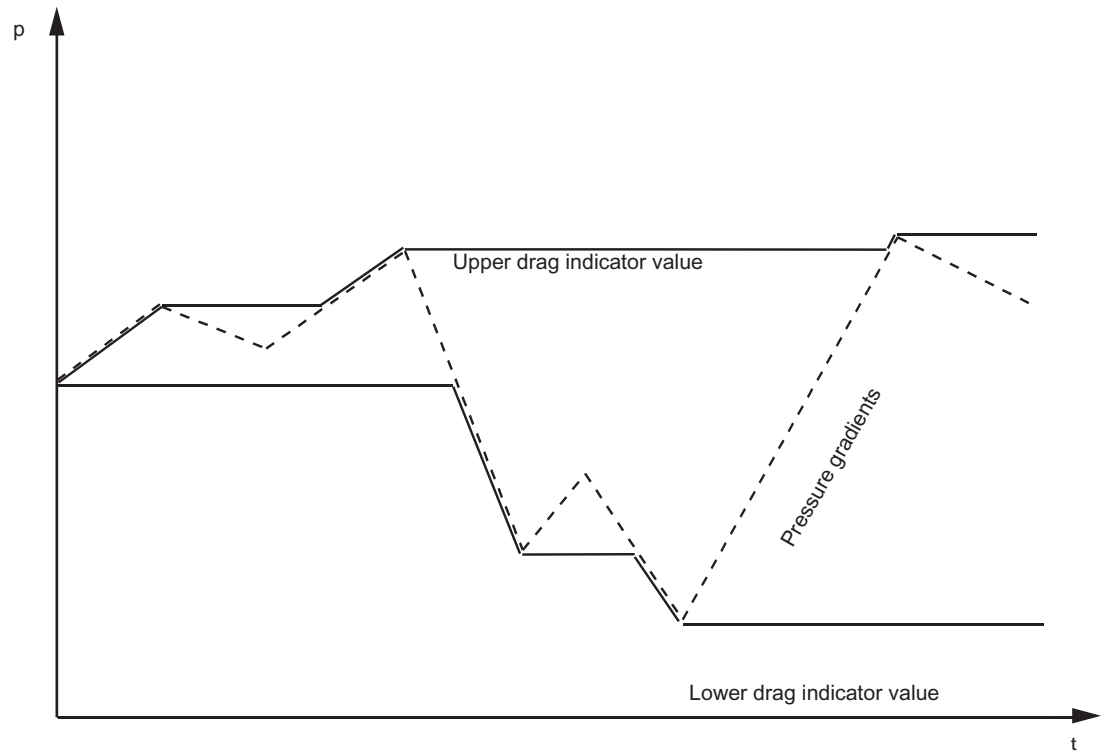

Figure 7-8 Basic representation of min/max pointers

p Pressure t Time

See also

Simulating the pressure sensor (Page 7-24)

Simulating sensor and electronics temperature (Page 7-26)

7.10 Simulation

7.10.1 Overview of simulation

Simulation functions help you when commissioning parts of the system and the transmitter. You can generate process values without recording real measured values. The value range of simulated process values can be tested fully: This makes the simulation of errors possible.

From the output of the pressure transmitter, you can get ever closer to the sensor, thus checking the measurement and function blocks.

The digital display indicates active simulation with an "Si" in the mode display.

7.10.2 Simulating output

By simulating the output, you can make process values available on the output of the pressure transmitter for cyclical data transmissions via acyclic write access. This allows you to test process value processing in the automation program.

Procedure

To simulate the output, make the following settings:

1. Select output simulation.
2. Set the target mode to manual (MAN).
3. Enter the desired output value, the quality, and the status.
4. Transmit the settings from the program into the transmitter.

The behavior of the output can be observed e.g. in SIMATIC PDM or using a variable table (VAT component).

To return to normal operation afterwards, set the target mode to AUTO.

7.10.3 Simulating input

Simulation of the input allows you to adjust the measured value to the desired process value to check monitoring of your preset process limits, electrical damping, and failure behavior.

Procedure

To simulate the input, make the following settings:

1. Select input simulation.
2. Set the target mode to AUTO.
3. Select the simulation mode "Released".
4. Enter the desired input value, the quality, and the status.
5. Transmit the settings from the program into the transmitter.

You can observe the behavior of the input in e.g. SIMATIC PDM.

To return to normal operation afterwards, you must turn off the simulation.

7.10.4 Simulating the pressure sensor

By simulating the pressure sensor as a fixed value or a parameterizable ramp, you can check the following functions:

- Calibration
- Check the zero-point adjustment
- Reaction to violation of sensor limits

- Linearization
- Projection onto the working range

You can make the simulation value dynamic with a parameterizable ramp. It then moves from a starting value (v_1) in a step function to a final value (v_2), staying at each level for the given step interval (t_v). At the final value, the direction reverses.

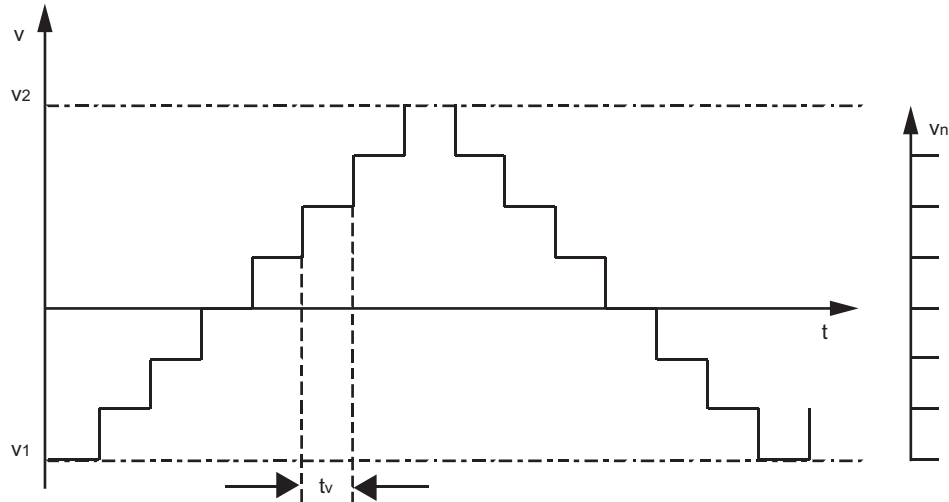

Figure 7-9 Parameterizable ramp

v	Value	t	Time
v_1	Starting value	t_v	Step interval
v_2	Final value	v_n	Number of steps

Procedure

To simulate the pressure sensor, make the following settings:

1. Select pressure sensor simulation.
2. Set the simulation mode and the parameters:
 - Simulation mode "Fixed" and parameter pressure value
 - Simulation mode "Ramp" and ramp parameters
3. Transmit the settings from the program into the transmitter.

The behavior of the measured value (primary variable), the secondary variables 1, 2, and 3, and of the output, can be observed in SIMATIC PDM.

To return to normal operation afterwards, you must turn off the simulation.

7.10.5 Simulating sensor and electronics temperature

By simulating the sensor and electronics temperature you can, for instance, check the influence of excessive temperature on the measurement results:

Procedure

To simulate the sensor and electronics temperature, make the following settings:

1. Select the simulation of sensor or of the electronics temperature.
2. Set the simulation mode and the parameters:
 - Simulation mode "Fixed" and parameter pressure value
 - Simulation mode "Ramp" and ramp parameters
3. Transmit the settings from the program into the transmitter.

The behavior of the measured value (primary variable), the secondary variables 1, 2, and 3, and of the output, can be observed in SIMATIC PDM.

To return to normal operation afterwards, you must turn off the simulation.

7.11 Calibrating the sensor

Sensor calibration enables you to calibrate the transmitter. Analogously to mode 19 and 20 for local operation, you can change the slope of the characteristic curve of the transmitter.

Using a lower and an upper calibration point, you can determine the course of the characteristic curve.

Change the slope of the characteristic to a minimum of 0.9 and a maximum of 1.1. Any larger variation from a slope of 1.0 will prevent the calibration point from being stored.

The lower calibration point must be far enough from the upper point that the smallest calibration span is included.

The smallest calibration span is displayed in the sensor calibration dialog and depends on the measurement range. If the calibration is smaller than the smallest span, the following status code accompanies the measured value:

"Bad, configuration error"

In this case, recalibrate the lower or the upper calibration point with a sufficiently large calibration span.

Calibrating the lower point

To calibrate the lower point, proceed as follows:

1. Call up the dialog "Sensor calibration".
2. Apply the reference pressure for the lower calibration point.
3. Enter the value of the reference pressure in the field "lower calibration point".
4. Click on "Transmit".

In the field "Pressure cleaned raw value", observe the effect of the calibration. In the field "Lower calibration point" you can tell whether the new calibration point was accepted.

Calibrating the upper point

To calibrate the upper point, proceed as follows:

1. Call up the dialog "Sensor calibration".
2. Switch to the "Upper calibration" tab.
3. Apply the reference pressure for the upper calibration point.
4. Enter the value of the reference pressure in the field "upper calibration point".
5. Click on "Transmit".

In the field "Pressure cleaned raw value", observe the effect of the calibration. In the field "Upper calibration point" you can tell whether the new calibration point was accepted.

After both points have been calibrated, the status of the measured value must be "Good". If the status "Bad, configuration error" is displayed, the calibration was smaller than the smallest calibration span. You must move the calibration points away from one another by moving one of the two calibration points.

See also

LO calibration (Page 6-22)

HI calibration (Page 6-24)

7.12 Correcting for positional error

External influences can affect the original zero point. External influences include:

- Installation position
- Ambient temperature
- Installation-caused preset pressures, for instance fluid columns in the pressure line to the transmitter

You can correct for these influences within the following limits.

Pressure	-100 %, but not more than -1 bar up to +100 % of the nominal measurement range
Absolute pressure	Correction for positional error not possible

Procedure

To correct for positional error, proceed as follows:

1. Call up the dialog "Correct for positional error".
2. Create a pressure calibration.
3. Click on "Transmit".

7.13 Resetting

7.13.1 Resetting to delivery state

If the pressure transmitter is so maladjusted that it can no longer fulfill its measurement tasks, you can use this function to reset it to the factory settings. It resets all parameters to the factory settings, with a few exceptions.

The exceptions are:

- PROFIBUS address
- Device operation type
- Static version number
 - In Transducer Block 1
 - In the analog input function block

The reset is indicated by the diagnostic message "New start executed". The automation or control system reads the status "Unsure, initial value, value constant" until a measured value result is available.

See also

Device operation type (Page 6-19)

Resetting the PROFIBUS address (Page 7-28)

7.13.2 Warm start/restart

With a warm start, you have the pressure transmitter switch itself off and restart. This interrupts and then reestablishes communication.

You need this function, for example, if the PROFIBUS address is changed during running communication with a cyclical master.

This restart is indicated by the diagnostic message "Restart executed". The automation or control system reads the status "Unsure, initial value, value constant" until a measured value result is available.

7.13.3 Resetting the PROFIBUS address

If no other pressure sensor in your system has the preset address 126, you can add your transmitter to the PROFIBUS strand during running operation of the automation or control system. Then you must change the address of the newly connected unit to a different value.

If you remove a transmitter from the PROFIBUS strand, reset its address to 126 so that you can add it back into this system or another if needed.

Configuration/projection

8.1 Cyclical data transfer

Cyclical data transmission is used to transfer data relevant for process automation between the control or automation system (class 1 master) and the transmitter.

Setting the PROFIBUS address

The PROFIBUS is set to 126 at the factory. You set it at the device or using a parameterization tool through the bus, e.g.:

- SIMATIC PDM
- HW config.

The new address will take effect either after the first warm start or when the device is disconnected temporarily from the bus.

8.2 Configuration

8.2.1 Overview of configuration

General

Information on the input and output range as well as the consistency of cyclically transmitted data is defined in the device master data file (GSD file). Using the configuration packet, it is checked by the device and declared valid. During projection it must be determined which data will be transmitted in cyclical operation. This allows the optimization of the data quantity to be transmitted. In the Siemens control system, the GSD files of all the usual devices are already available, and they are also available on the Internet and can be imported later.

Reference

http://www.ad.siemens.de/csi_e/gsd

8.2.2 Configuration of user data

The user data which are provided through the PROFIBUS to the control system are based on the selected target configuration. User data is generated by the function blocks and assembled in the following order:

Note

The totalizer function block can be selected, but is not relevant for gauge or absolute pressure.

Analog input function block

The analog input function block supplies the content of the "Output" parameter, and the counter function block that of the "counter output" parameter. You can select in the configuration which function block is used to generate the output data:

- Output
- Totalizer output

In the "Totalizer output" parameter you can insert the following additional functions:

- Reset totalizer output
- Operating mode

Using "Reset totalizer output" you can reset the integrator from the application program, and with "Operating mode" you can determine its function.

Note

For STEP 7, the configuration tool is HW-Konfig.

For STEP 5, it is COM_PROFIBUS.

User data

Table 8-1 User data dependent on the selected function block

Function block / parameter	Byte	User data, sent to master	User data, sent from master	Meaning, depending on parameter
Analog input/output	1.-4.	Measured value	---	Pressure, height, volume, sensor temperature, electronics temperature
	5.	Status		
Totalizer / totalizer output	6.-9.	Measured value	---	Mass or volume
	5.	Status		

Table 8-2 User data, dependent on selected additional function in the totalizer output function block

Additional function	Byte	User data, sent to master	User data, sent from master	Meaning
Reset totalizer output	1.	---	Reset totalizer output	Totalizer reset function
				0 Normal operation of totalizer Integration running.
				1 Step integration and reset integrator back to 0.
				2 Stop integration and load integrator with preset value.
Operating mode	2.	---	Operating mode	Operating mode of totalizer
				0 Net counter - count up and down.
				1 Ascending counter
				2 Descending counter
				3 Hold count.

See also

Analog input function block (Page 7-9)

8.2.3 Transmission of user data over PROFIBUS

User data is continually updated via PROFIBUS cyclical data transmission.

Table 8-3 IEEE standard floating point representation of the measured value

Bits	7	6	5	4	3	2	1	0
Byte 1	VZ	E 2 ⁷	E 2 ⁶	E 2 ⁵	E 2 ⁴	E 2 ³	E 2 ²	E 2 ¹
Byte 2	E 2 ⁰	E 2 ⁻¹	M 2 ⁻²	M 2 ⁻³	M 2 ⁻⁴	M 2 ⁻⁵	M 2 ⁻⁶	M 2 ⁻⁷
Byte 3	M 2 ⁻⁸	M 2 ⁻⁹	M 2 ⁻¹⁰	M 2 ⁻¹¹	M 2 ⁻¹²	M 2 ⁻¹³	M 2 ⁻¹⁴	M 2 ⁻¹⁵
Byte 4	M 2 ⁻¹⁶	M 2 ⁻¹⁷	M 2 ⁻¹⁸	M 2 ⁻¹⁹	M 2 ⁻²⁰	M 2 ⁻²¹	M 2 ⁻²²	M 2 ⁻²³

VZ Sign
 0 positive
 1 negative
 M mantissa
 E exponent

8.2.4 Status

The status provides information on:

- Usability of the measured value in the application program
- Device status, e.g. self-diagnosis or system diagnostic
- Additional process information, for instance process alarms

The status code consists of one letter and a three-digit number. The letter stands for:

G	Good
U	Unsure
B	Bad

Table 8-4 Example status code

Digital display	Hex	Configured measured value source	PDM display	Cause	Measure
G_141	8D	Electronics temperature, output	Good, lower alarm limit violated	Lower configured alarm limit violated.	Correct error through user program.
U_071	47	Output	Unsure, last usable value, value constant	Input condition "fail safe" is fulfilled, the parameterized safety setting is set to "keep last valid value".	Check the data measurement.
B_011	0B	Secondary variable 3	Bad, not connected, value constant	Variable is not calculated,	Correct the "transmitter type" setting.

See also

Overview of status codes (Page A-2)

8.2.5 Diagnosis

Besides status information, the device can also actively send information about its own state. Diagnostics are important information which an automation system can use to initiate corrective measures.

To transmit diagnostic information, the standard mechanisms of the PROFIBUS DP are used and messages are actively sent to the class 1 master. PROFIBUS DP provides a protocol to transmit information to the class 1 master with a higher priority than the user data.

Messages

The content of the "Device state" parameter from the physical block is sent, along with information about whether a state change (event incoming/event sent) has occurred.

The diagnostic object consists of four bytes. For the SITRANS P300, only the first two bytes are relevant.

Table 8-5 Diagnostic messages

Byte	Bit	Meaning of "1"	Cause	Measure
Byte 0	0			
	1			
	2			
	3	Electronics temperature too high	The transmitter monitors the temperature of the transmitter electronics. If this exceeds 85 °C, this message is generated.	Reduce the ambient temperature to the allowed range.
	4	Memory error	During operation, the memory of the cells and the electronics is continually checked for checksum errors and read/write errors. In case of error, this message is generated.	Replace the electronics and, if necessary, the sensor.
	5	Error recording measured value	In case of sensor failure or the violation of control limits (< -20% or > +20% of the nominal measurement range)	Have a service technician check the sensor.
	6			
Byte 1	7			
	0			
	1			
	2			
	3	Restart executed (goes to "0" after 10 seconds)	Power was applied to the device, or a warm start was performed using SIMATIC PDM, or the internal watchdog triggered.	Check the wiring and the power supply.
	4	New start Goes to "0" after 10 seconds	The device was reset to the factory settings.	
	5	Service necessary	A calibration or service interval has run out.	Perform the calibration or service and clear the message and reset the messages using SIMATIC PDM.
6				

Byte	Bit	Meaning of "1"	Cause	Measure
	7	Ident number changed	You changed the parameter "PROFIBUS Ident Number" during cyclical operation. The device signals the change to the ident number and shows a shutdown warning. In case of a restart, the device will no longer participate in cyclical user data exchange unless the system configuration is changed.	Make a change to the configuration data (change the GSD file) so that it matches the ident number configured in the device.

Note

The device state can be simulated using SIMATIC PDM. This allows you to check the reaction of the automation system to an error.

8.3 Acyclic data transfer

Acyclic data transmission is used primarily for the transmission of parameters:

- During commissioning
- During service
- In batch processes
- To display additional measurement data which is not sent during cyclic user data transmission, e.g. raw pressure value

The data traffic between a class 2 master and the field device occurs over a so-called C2 connection. So that multiple class 2 masters can access the same transmitter at the same time, the device supports up to four C2 connections. However, you must ensure that the same data is not being written.

Commissioning

9.1 Safety instructions for commissioning



Warning
Intrinsically safe circuits

In intrinsically safe circuits, use only certified power supplies or couplers which match the transmitter.



Warning
Specific type examination certificates

Observe the EG type examination certificate or the type examination certificate valid for your country.



Warning
"Intrinsically safe"

If a non-conforming supply unit is used, the "intrinsically safe" protection type will no longer be effective and the approval certification will be invalid.



Warning
Fixed installation

Devices to be operated in hazardous areas should be connected with fixed cable installation. This is not necessary with intrinsically safe devices or devices with "nL" – "limited energy" protection.



Warning
Tightness

Use cable with a diameter of 7 to 12 mm for protection class IP65 through IP68.



Warning
Hot media

Perform work steps with hot media immediately one after the other. Otherwise the valves and pressure transmitter will become too hot and be damaged.



Warning
Toxic media

If you use the pressure transmitter with toxic media, ventilation of the transmitter is not permitted.

Notice

Before commissioning, check the basic parameters.

Due to changes in the operating functions, displays and the measurement output could be set such that the true process pressure is not reproduced.

9.2 Instructions for commissioning

Note

To obtain stable measured values, the transmitter needs to be allowed to warm up for five minutes or so after the power supply is switched on.

Note

The operating data have to correspond to the values on the nameplate. When you switch the auxiliary power on, the transmitter is in operation.

9.3 Introduction to commissioning

Following commissioning, the transmitter is immediately ready for use.

To obtain stable measured values, the transmitter needs to be allowed to warm up for five minutes or so after the power supply is switched on.

The measuring span which can be set corresponds to the information on the nameplate. Even in the case of a customer-specific setting configured in the factory, the zero point and the limit point will appear on the nameplate.

If need be, you can change the parameters by simple user operations on the device even during commissioning.

9.4 Commissioning with steam or liquid

Overview

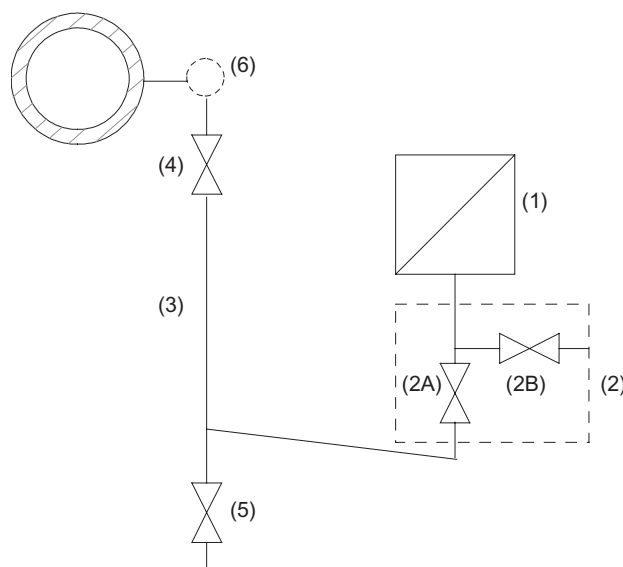

Figure 9-1 Measuring steam

- (1) Pressure transmitter
- (2) Shut-off module

- (2A) Shut-off valve to process
- (2B) Shut-off valve for test connection or for bleed screw
- (3) Pressure line
- (4) Shut-off valve
- (5) Drain valve
- (6) Compensation vessel (steam only)

Requirement

All valves are closed.

Procedure

To commission the transmitter for steam or liquid, proceed as follows:

1. Open the shut-off valve for the test connection (2B).
2. Via the test connection of the shut-off module (2), apply the pressure corresponding to the zero point to the pressure transmitter (1).
3. Check the zero point.
4. If the zero point differs from the value desired, correct it.
5. Close the shut-off valve for the test connection (2B).
6. Open the shut-off valve (4) at the pressure tapping point.
7. Open the shut-off valve to the process (2A).

9.5 Commissioning for gases

Overview

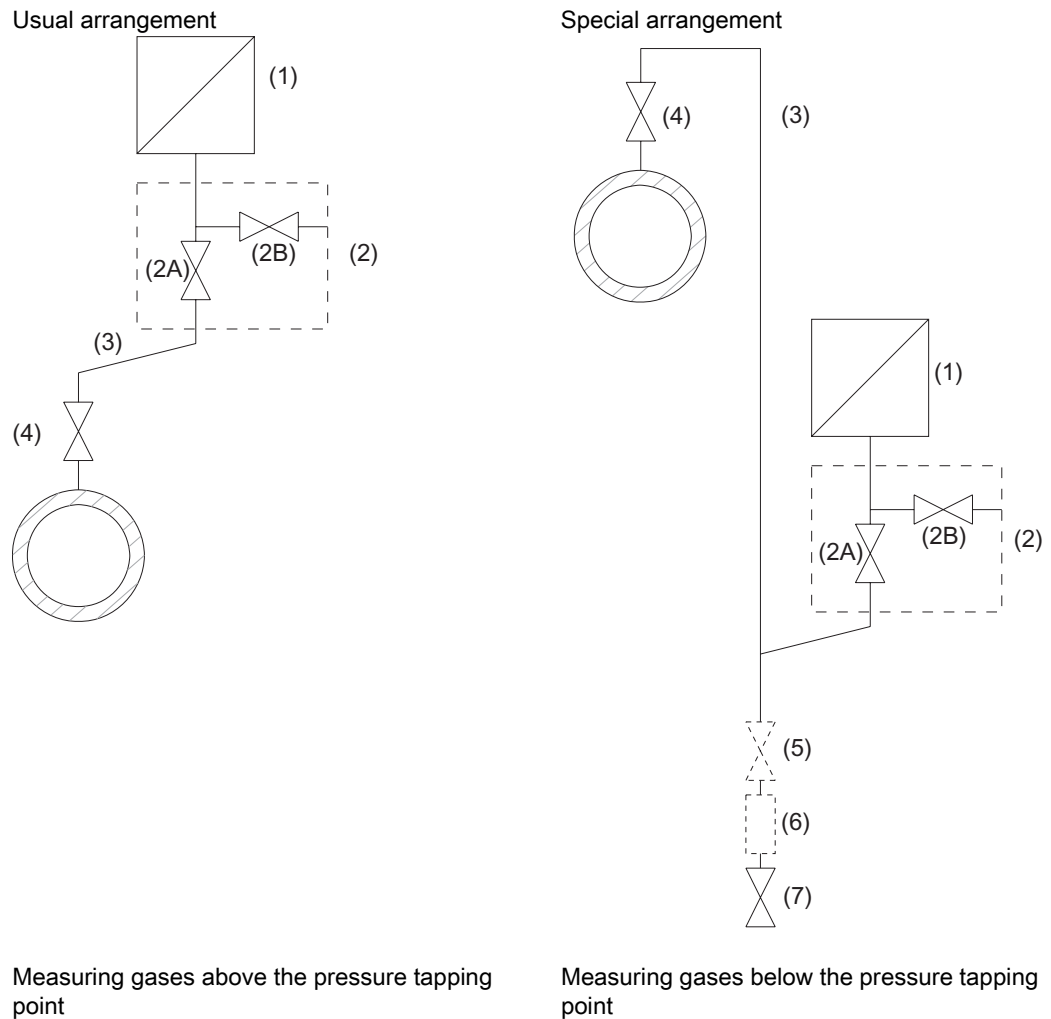

- (1) Pressure transmitter
- (2) Shut-off module
- (2A) Shut-off valve to process
- (2B) Shut-off valve for test connection or for bleed screw
- (3) Pressure line
- (4) Shut-off valve
- (5) Shut-off valve (optional)
- (6) Condensation vessel (optional)
- (7) Drain valve

Requirement

All valves are closed.

Procedure

To commission the transmitter for gases, proceed as follows:

1. Open the shut-off valve for the test connection (2B).
2. Via the test connection of the shut-off module (2), apply the pressure corresponding to the zero point to the pressure transmitter (1).
3. Check the zero point.
4. If the zero point differs from the value desired, correct it.
5. Close the shut-off valve for the test connection (2B).
6. Open the shut-off valve (4) at the pressure tapping point.
7. Open the shut-off valve to the process (2A).

Error and system messages

10.1 Errors

Errors and error correction

Errors	Cause	Measure
Measured value		
Measured value shows up on the digital display but is not displayed in the control system.	<ul style="list-style-type: none"> Mode 15 	<ul style="list-style-type: none"> Check whether the bus address on the device matches the bus address in the control system. If it does not match, correct the bus address.
	<ul style="list-style-type: none"> Mode 16 	<ul style="list-style-type: none"> Set "ident" in mode 16.

Table 10-1 Error message

Digital display	PDM display	Cause	Measure
F_001	-	Local operation blocked.	Remove write protection.
F_003	-	Changes to the bus address and device operating type are not possible, since the device is in communication with a class 1 master.	End communication with class 1 master.
F_004	-	Display overflow.	Check settings of physical unit and position of decimal point, and adjust to the current measured value.
F_005	-	Value is read-only.	-
F_006	-	Correction not successful.	Check calibration span and repeat procedure.
F_007	-	After zero-point calibration, measurements no longer possible in entire measurement range.	Check measurement range, decrease correction if necessary.
F_008	-	Local operation blocked by SIMATIC PDM.	Use SIMATIC PDM to set the "Local operation" parameter to "released".

See also

Overview of status codes (Page A-2)

Specifications

11.1 SITRANS P300 gauge pressure / absolute pressure

Specifications

Gauge pressure input	
Measured variable	Gauge pressure
Measuring range	Maximum permissible operating pressure
<ul style="list-style-type: none"> • 250 mbar g (3.6 psi g) • 1 bar g (14.5 psi g) • 4 bar g (58 psi g) • 16 bar g (232 psi g) • 63 bar g (914 psi g) • 160 bar g (2321 psi g) • 400 bar g (5802 psi g) 	<ul style="list-style-type: none"> 2 bar g (29 psi g) 4 bar g (58 psi g) 7 bar g (102 psi g) 21 bar g (305 psi g) 67 bar g (972 psi g) 167 bar g (2422 psi g) 400 bar g (5802 psi g)
Lower measuring limit	
<ul style="list-style-type: none"> • Measuring cell with silicone oil • Measuring cell with inert liquid 	30 mbar a (0.44 psi a)
For temperature of medium ϑ	
-20 °C < ϑ ≤ 60 °C (-4 °F < ϑ ≤ 140 °F)	30 mbar a (0.44 psi a)
For temperature of medium ϑ	
60 °C < ϑ ≤ 100 °C (140 °F < ϑ ≤ 212 °F)	30 mbar a + 20 mbar a • (ϑ - 60 °C)/°C (0.44 psi a + 0.29 psi a • (ϑ - 108 °F)/°F)
Upper measuring limit	
<ul style="list-style-type: none"> • Measuring cell with silicone oil • Measuring cell with inert liquid 	100% of maximum measuring span 100% of maximum measuring span Max. 160 bar g (2320 psi g) for oxygen measurement
Absolute pressure input	
Measured variable	Absolute pressure
Measuring range	Maximum permissible operating pressure
<ul style="list-style-type: none"> • 250 mbar a (3.6 psi a) • 1.30 bar a (19 psi a) • 5 bar a (73 psi a) 	<ul style="list-style-type: none"> 1.5 bar a (22 psi a) 2.6 bar a (38 psi a) 10 bar a (145 psi a)

Specifications

11.1 SITRANS P300 gauge pressure / absolute pressure

Absolute pressure input	
• 30 bar a (435 psi a)	45 bar a (653 psi a)
Lower measuring limit	
• Measuring cell with silicone oil	0 mbar a (0 psi a)
Upper measuring limit	
• Measuring cell with silicone oil	100% of maximum measuring span

Output	
Output signal	Digital PROFIBUS PA signal
Bus physics	IEC 61158-2
Polarity independent	Yes
Electrical damping T ₆₃ (step width 0.1 s)	Set to 0.1 s (0 ... 100 s)

Measuring accuracy	
Reference conditions	<ul style="list-style-type: none"> • Rising characteristic curve • Zero point 0 bar • Seal diaphragm: stainless steel • Measuring cell with silicone oil Room temperature 25 °C (77 °F)
Measurement deviation with cut-off point setting, including hysteresis and repeatability.	
Linear characteristic curve	≤ 0,075 %
Repeatability and hysteresis	Included in measurement deviation
Settling time T ₆₃ without electrical damping	About 0.2 sec
Long-term drift at ±30 °C (±54 °F)	In 5 years
	≤ 0,25 %
Influence of ambient temperature	As percentage
• At -10 ... +60 °C (14 ... 140 °F)	≤ 0,3 %
• At -40 ... -10 °C and +60 ... +85 °C (-40 ... 14 °F and 140 ... 185 °F)	≤ 0.25% per 10 K
Influence of installation position	In pressure per change of angle
	0.4 mbar (0.006 psi) per 10°
	Correction via zero point calibration
Measurement resolution	3 • 10 ⁻⁵ of nominal measurement range

Operating conditions	
Installation conditions	
Ambient temperature	
Observe the temperature class in areas subject to explosion hazard.	
• Measuring cell with silicone oil	-40 °C ... +85 °C (-40 °F ... 185 °F)

Operating conditions

• Measuring cell with inert liquid	-20 °C ... +85 °C (-4 °F ... 185 °F)
• Digital display	-30 °C ... +85 °C (-22 °F ... 185 °F)
• Storage temperature	-50 °C ... +85 °C (-58 °F ... 185 °F)
Climatic class	
• Condensation	Permissible
Degree of protection	IP65, IP68, NEMA 4X, enclosure cleaning, resistant to lyes, steam to 150° C
As per EN 60 529	
Electromagnetic compatibility	
• Disruption transmission and resistance	As per EN 61 326 and NAMUR NE 21
Process conditions	
Process temperature	
• Measuring cell with silicone oil	-40 °C ... +100 °C (-40 °F ... 212 °F)
• Measuring cell with inert liquid	-20 °C ... +100 °C (-4 °F ... 212 °F)

Design

Weight (without options)	About 800 g (1.8 lb)
Material	
Wetted parts materials	
• Connection pins	Stainless steel, mat. no. 1.4404/316L Hastelloy C276, mat. no. 2.4819
• Oval flange	Stainless steel, mat. no. 1.4404/316L
• Separating diaphragm	Stainless steel, mat. no. 1.4404/316L Hastelloy C276, mat. no. 2.4819
Non-wetted parts materials	
• Electronics housing	Electropolished stainless steel, mat. no. 1.4301
Measuring cell filling	<ul style="list-style-type: none"> • Silicone oil • Inert liquid
Process connection	<ul style="list-style-type: none"> • G½A as per DIN EN 837-1 • Internal thread ½-14 NPT • Oval flange PN 160 (MWP 2320 psi) with fastening thread: <ul style="list-style-type: none"> - 7/16-20 UNF as per IEC 61518 - M10 as per DIN 19213
Electrical connection	<ul style="list-style-type: none"> • Cable entry via threaded connection M20x1.5 (metal with screening)

Auxiliary power U_H

Auxiliary power	Bus-powered
Separate power supply	Not needed
Bus voltage	
• Without EEx	9 ... 32 V
• In intrinsically safe operation	9 ... 24 V

Specifications

11.1 SITRANS P300 gauge pressure / absolute pressure

Auxiliary power U_H	
Power consumption	
• Maximum basic current	12.5 mA
• Starting current ≤ basic current	Yes
• Maximum current in case of failure	15.5 mA
Failure shutdown electronics (FDE)	Included

Certificates and approvals	
Classification according to Pressure Equipment Directive (PED 97/23/EC)	For gases of Fluid Group 1 and liquids of Fluid Group 1; meets requirements of Article 3 Para. 3 (Good engineering practice)
Water, waste water	In preparation
CENELEC explosion protection	
Ignition protection class "i" intrinsically safe	PTB 05 ATEX 2048
• Identification	Ex II 1/2 G EEx ia/ib IIB/IIC T4, T5, T6
• Permissible ambient temperature	-40 ... +85 °C (-40 ... +185 °F) Temperature class T4 -40 ... +70 °C (-40 ... +158 °F) Temperature class T5 -40 ... +60 °C (-40 ... +140 °F) Temperature class T6
• Connection	
To certified intrinsically safe circuits with maximum values:	
FISCO power supply	U _i = 17.5 V, I _i = 380 mA P _i = 532 W
Linear barriers	U _i = 24 V, I _i = 250 mA P _i = 1.2 W
• Effective inner capacitance:	C _i = 1.1 nF
• Effective inner inductance:	L _i = 7 µH

Communication	
Simultaneous communication with class 2 masters	Max. 4
Address setting possible using	• configuration tool • local operation (Default address 126)
Cyclical user data	
• Output byte	• One measured value: 5 bytes • Two measured values: 10 bytes
• Input byte	• Totalizer operation mode: 1 byte • Reset function due to dosage: 1 byte
Device profile	PROFIBUS PA Profile for Process Control

Communication	
	Devices Version 3.0, Class B
Function Blocks	2
<ul style="list-style-type: none"> Analog input 	Linearly increasing or falling characteristic 0 to 100 sec possible Output/input Parameterizable as: <ul style="list-style-type: none"> Last good value Replacement value Erroneous value
Adjustment to user-specific process values Electrical damping T_{63} Simulation function Failure behavior	
<ul style="list-style-type: none"> Limit value monitoring 	An upper and lower warning and alarm limit
<ul style="list-style-type: none"> Totalizer 	<ul style="list-style-type: none"> Resettable and presettable Counting direction selectable Simulation function of totalizer output
Failure behavior	Parameterizable as: <ul style="list-style-type: none"> Sum of last good value Stop summing Sum with erroneous value
Limit value monitoring	An upper and lower warning and alarm limit
Physical Block	1
Transducer blocks	2
<ul style="list-style-type: none"> Pressure transducer block 	
Can be calibrated by applying two pressures Monitoring of sensor limits Specification of a container characteristic curve Characteristic curve	Yes Yes With maximum 31 set points <ul style="list-style-type: none"> Linear Root extraction
Creep quantity suppression and use of root extraction Not for gauge or absolute pressure	Parameterizable Not for gauge or absolute pressure
Simulation function <ul style="list-style-type: none"> Measured pressure value Sensor temperature 	<ul style="list-style-type: none"> Constant value Parameterizable ramp function Constant value Parameterizable ramp function
<ul style="list-style-type: none"> Electronic temperature transducer block 	
Simulation function <ul style="list-style-type: none"> Measured pressure value Electronics temperature 	<ul style="list-style-type: none"> Constant value Parameterizable ramp function Constant value Parameterizable ramp function

11.2 SITRANS P300 gauge pressure / absolute pressure (flush-mounted)

Specifications

Input	
Measured variable	Gauge pressure (flush-mounted)
Measuring range	Maximum permissible operating pressure
<ul style="list-style-type: none"> • 250 mbar g (3.6 psi g) • 1 bar g (14.5 psi g) • 4 bar g (58 psi g) • 16 bar g (232 psi g) • 63 bar g (914 psi g) 	<ul style="list-style-type: none"> 2 bar g (29 psi g) 4 bar g (58 psi g) 7 bar g (102 psi g) 21 bar g (305 psi g) 67 bar g (972 psi g)
Depending on the process connection, the measuring span may differ from these values.	
Lower measuring limit	
<ul style="list-style-type: none"> • Measuring cell with silicone oil 	30 mbar a (0.44 psi a)
Upper measuring limit	
<ul style="list-style-type: none"> • Measuring cell with silicone oil 	100% of maximum measuring span

Output	
Output signal	Digital PROFIBUS PA signal
Bus physics	IEC 61158-2
Polarity independent	Yes
Electrical damping T ₆₃ (step width 0.1 s)	Set to 0.1 s (0 ... 100 s)

Measuring accuracy	
Reference conditions	<ul style="list-style-type: none"> • Rising characteristic curve • Zero point 0 bar • Seal diaphragm: stainless steel • Measuring cell with silicone oil <p>Room temperature 25 °C (77 °F)</p>
Measurement deviation with cut-off point setting, including hysteresis and repeatability.	
Linear characteristic curve	≤ 0,075 %
Settling time T ₆₃ without electrical damping	Approx. 0.2 s
Long-term drift at ±30 °C (±54 °F)	In 5 years
	≤ 0,25 %
Influence of ambient temperature	As percentage
<ul style="list-style-type: none"> • at -10 ... +60 °C (14 ... 140 °F) • at -40 ... -10 °C and +60 ... +85 °C • (-40 ... 14 °F and 140 ... 185 °F) 	<ul style="list-style-type: none"> ≤ 0,3 % ≤ 0.25% per 10 K
Influence of process temperature	In pressure per change of temperature

11.2 SITRANS P300 gauge pressure / absolute pressure (flush-mounted)

Measuring accuracy

• Temperature difference between the process temperature and the ambient temperature	3 mbar per 10 K (0.04 psi per 10 K)
Influence of installation position	In pressure per change of angle 0.4 mbar (0.006 psi) per 10° Correction via zero point calibration
Measurement resolution	$3 \cdot 10^{-5}$ of nominal measurement range

Operating conditions

Installation conditions	
Ambient temperature	
Observe the temperature class in areas subject to explosion hazard.	
• Measuring cell with silicone oil	-40 °C ... +85 °C (-40 °F ... 185 °F)
• Digital display	-30 °C ... +85 °C (-22 °F ... 185 °F)
• Storage temperature	-50 °C ... +85 °C (-58 °F ... 185 °F)
Climatic class	
• Condensation	Permissible
Degree of protection	IP65, IP68, NEMA 4X, enclosure cleaning, resistant to lyes, steam to 150° C
As per EN 60 529	
Electromagnetic compatibility	
• Disruption transmission and resistance	As per EN 61 326 and NAMUR NE 21
Process conditions	
Process temperature	
• Measuring cell with silicone oil	-40 °C ... +150 °C (-40 °F ... 302 °F) -25 °C ... +200 °C (-13 °F ... 392 °F) with temperature decoupler

Design

Weight	Approx. 1 ... 13 kg (2.2 ... 29 lb)
Material	
Wetted parts materials	
• Process connection	Stainless steel, mat. no. 1.4404/316L
• Separating diaphragm	Stainless steel, mat. no. 1.4404/316L
Non-wetted parts materials	
• Electronics housing	Electropolished stainless steel, mat. no. 1.4301
Measuring cell filling	
	<ul style="list-style-type: none"> • Silicone oil • Neobee M20 • Medical white oil
Process connection	
	<ul style="list-style-type: none"> • Flanges as per EN and ASME • F&B and pharma flange • Bioconnect/Biocontrol • PMC Style

Design	
Electrical connection	<ul style="list-style-type: none"> • Cable entry via threaded connection M20x1.5 (metal with screening)
Auxiliary power U_H	
Auxiliary power	Bus-powered
Separate power supply	Not needed
Bus voltage	
<ul style="list-style-type: none"> • Without EEx 	9 ... 32 V
<ul style="list-style-type: none"> • In intrinsically safe operation 	9 ... 24 V
Power consumption	
<ul style="list-style-type: none"> • Maximum basic current 	12.5 mA
<ul style="list-style-type: none"> • Starting current ≤ basic current 	Yes
<ul style="list-style-type: none"> • Maximum current in case of failure 	15.5 mA
Failure shutdown electronics (FDE)	Yes
Certificates and approvals	
Classification according to Pressure Equipment Directive (PED 97/23/EC)	For gases of Fluid Group 1 and liquids of Fluid Group 1; meets requirements of Article 3 Para. 3 (Good engineering practice)
Water, waste water	In preparation
CENELEC explosion protection	
Ignition protection class "i" intrinsically safe	PTB 05 ATEX 2048
<ul style="list-style-type: none"> • Identification 	Ex II 1/2 G EEx ia/ib IIB/IIC T4, T5, T6
<ul style="list-style-type: none"> • Permissible ambient temperature 	-40 ... +85 °C (-40 ... +185 °F)
	Temperature class T4
	-40 ... +70 °C (-40 ... +158 °F)
	Temperature class T5
	-40 ... +60 °C (-40 ... +140 °F)
	Temperature class T6
<ul style="list-style-type: none"> • Connection 	
To certified intrinsically safe circuits with maximum values:	
FISCO power supply	U _i = 17.5 V, I _i = 380 mA
	P _i = 5.32 W
Linear barriers	U _i = 24 V, I _i = 250 mA
	P _i = 1.2 W
<ul style="list-style-type: none"> • Effective inner capacitance: 	C _i = 1.1 nF
<ul style="list-style-type: none"> • Effective inner inductance: 	L _i = 7 μH

Communication	
Simultaneous communication with class 2 masters	Max. 4
Address setting possible using	<ul style="list-style-type: none"> • configuration tool • local operation (Default address 126)
Cyclical user data	
<ul style="list-style-type: none"> • Output byte • Input byte 	<ul style="list-style-type: none"> • One measured value: 5 byte • Two measured values: 10 byte • Counter operation mode: 1 byte • Reset function due to dosage: 1 byte
Device profile	PROFIBUS PA Profile for Process Control Devices Version 3.0, Class B
Function Blocks	2
<ul style="list-style-type: none"> • Analog input Adjustment to user-specific process values Electrical damping T_{63} Simulation function Failure behavior	Linearly increasing or falling characteristic 0 to 100 sec possible Output/input Parameterizable as: <ul style="list-style-type: none"> • Last good value • Replacement value • Erroneous value
<ul style="list-style-type: none"> • Totalizer Limit value monitoring Failure behavior	An upper and lower warning and alarm limit <ul style="list-style-type: none"> • Resetable and presettable • Counting direction selectable • Simulation function of totalizer output Parameterizable as: <ul style="list-style-type: none"> • Sum of last good value • Stop summing • Sum with erroneous value
Limit value monitoring Physical Block	1
Transducer blocks	2
<ul style="list-style-type: none"> • Pressure transducer block Can be calibrated by applying two pressures Monitoring of sensor limits Specification of a container characteristic curve Characteristic curve	Yes Yes With maximum 31 set points <ul style="list-style-type: none"> • Linear • Root extraction Not for gauge or absolute pressure
Creep quantity suppression and use of root extraction Not for gauge or absolute pressure	Parameterizable

Communication

Simulation function

- Measured pressure value
 - Sensor temperature
 - Electronic temperature transducer block
- Constant value
 - Parameterizable ramp function
 - Constant value
 - Parameterizable ramp function

Simulation function

- Measured pressure value
 - Electronics temperature
- Constant value
 - Parameterizable ramp function
 - Constant value
 - Parameterizable ramp function
-

Dimension drawings

12.1 SITRANS P300 gauge pressure / absolute pressure

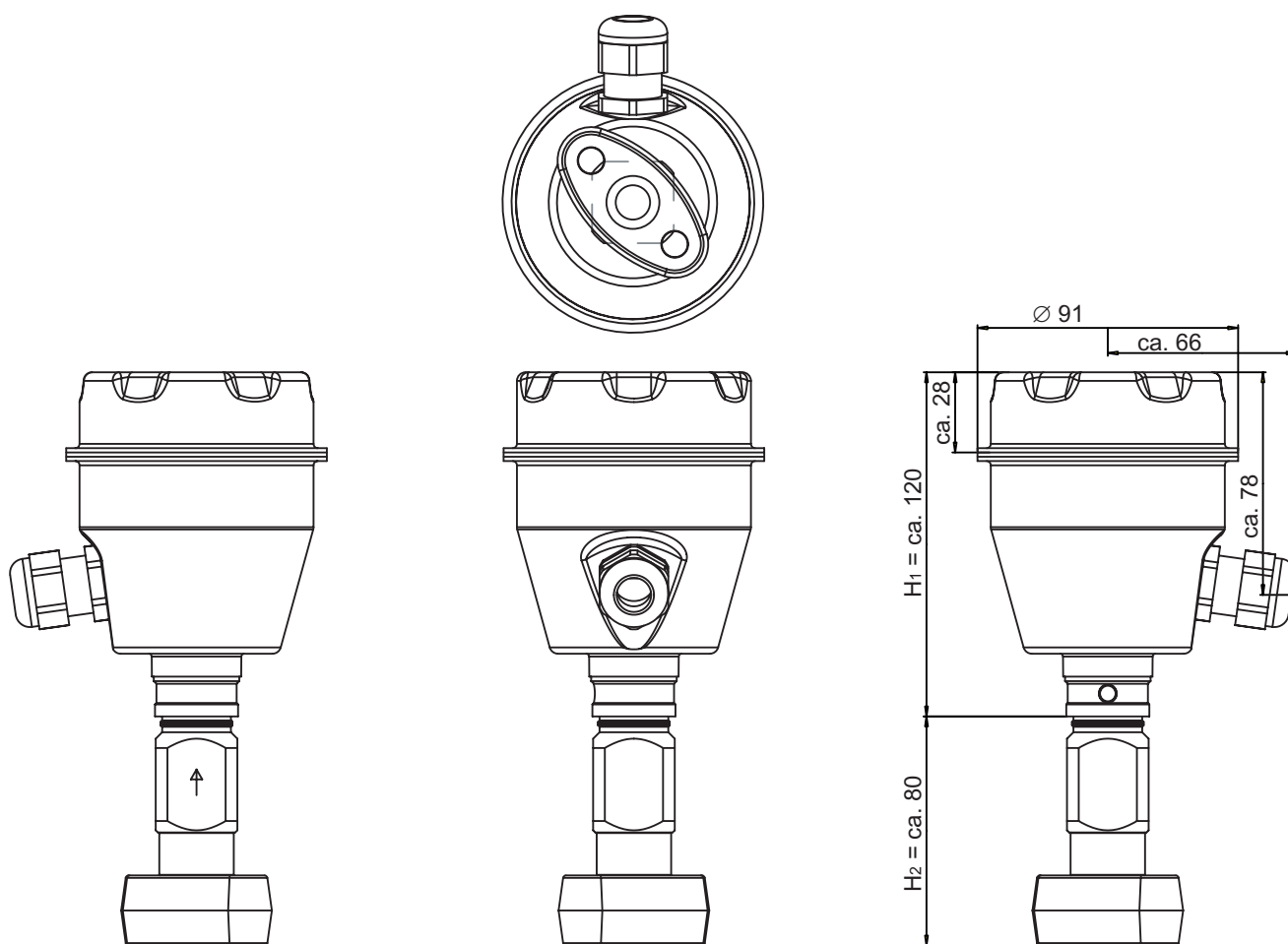

Figure 12-1 SITRANS P300 with oval flange

12.2 SITRANS P300 gauge pressure / absolute pressure (flush-mounted)

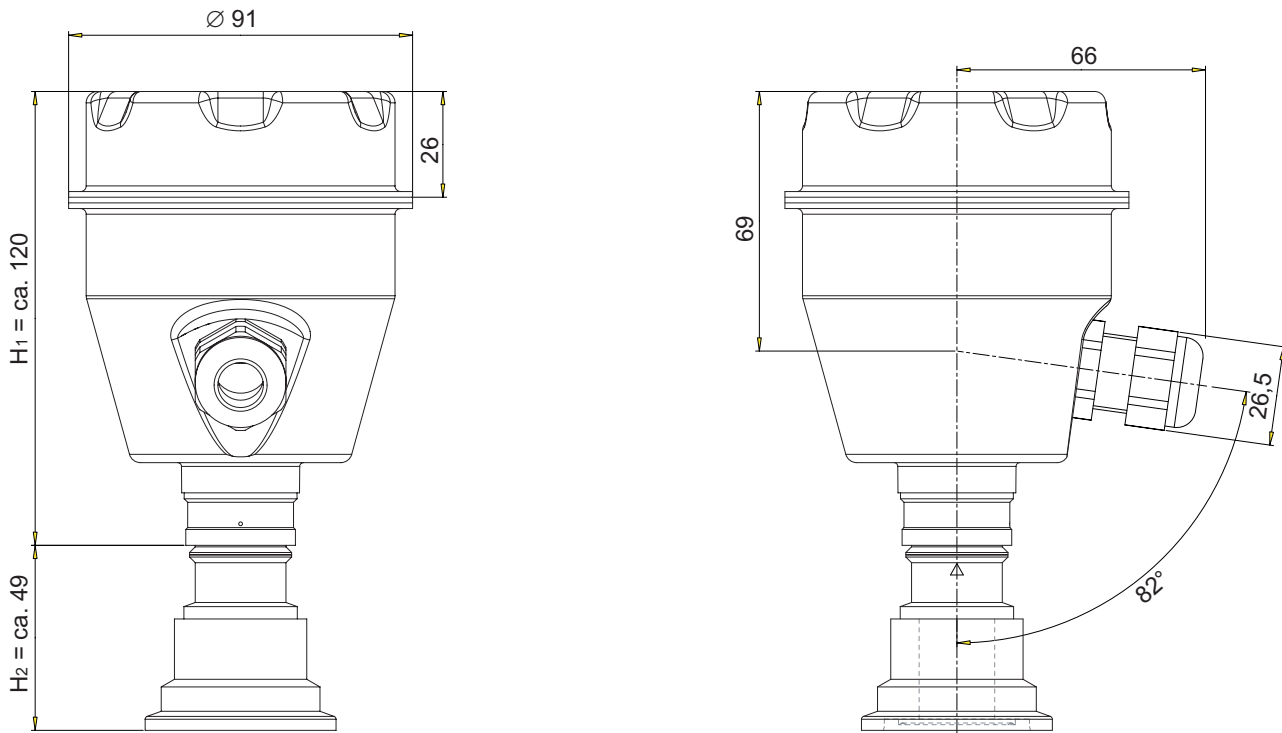

Figure 12-2 SITRANS P300 (flush-mounted)

The diagram shows a SITRANS P300 with an example of a flange. In this drawing the height is subdivided into H_1 and H_2 .

H_1 Height of the SITRANS P300 up to a defined cross-section

H_2 Height of the flange up to this defined cross-section

Height H_2 only is indicated in the dimensions of the flanges.

12.3 Flanges as per EN and ASME

Flange as per EN

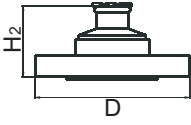
EN 1092-1				
	DN	PN	ØD	H ₂
	25	40	115 mm (4.5")	Approx. 55 mm (2.2")
	25	100	140 mm (5.5")	Approx. 55 mm (2.2")
	40	40	150 mm (5.9")	Approx. 55 mm (2.2")
	40	100	170 mm (6.7")	Approx. 55 mm (2.2")
	50	16	165 mm (6.5")	Approx. 55 mm (2.2")
	50	40	165 mm (6.5")	Approx. 55 mm (2.2")
	80	16	200 mm (7.9")	Approx. 55 mm (2.2")
	80	40	200 mm (7.9")	Approx. 55 mm (2.2")

Flanges as per ASME

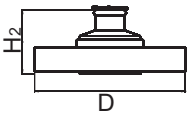
ASME B 16.5				
	DN	CLASS	ØD	H ₂
	1"	150	110 mm (4.3")	Approx. 53 mm (2.1")
	1"	300	125 mm (4.9")	Approx. 53 mm (2.1")
	1 1/2"	150	130 mm (5.1")	Approx. 53 mm (2.1")
	1 1/2"	300	155 mm (6.1")	Approx. 53 mm (2.1")
	2"	150	150 mm (5.9")	Approx. 53 mm (2.1")
	2"	300	165 mm (6.5")	Approx. 53 mm (2.1")
	3"	150	190 mm (7.5")	Approx. 53 mm (2.1")
	3"	300	210 mm (8.1")	Approx. 54 mm (2.1")
	4"	150	230 mm (9.1")	Approx. 53 mm (2.1")
	4"	300	255 mm (10.0")	Approx. 57 mm (2.2")

12.4 F&B and pharma flange

Connections as per DIN

DIN 11851

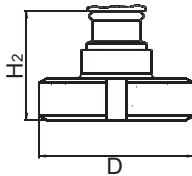

DN	PN	∅D	H ₂
25	40	63 mm (2.5")	Approx. 55 mm (2.2")
32	40	70 mm (2.8")	Approx. 55 mm (2.2")
40	40	78 mm (3.1")	Approx. 55 mm (2.2")
50	40	92 mm (3.6")	Approx. 55 mm (2.2")
80	40	127 mm (5")	Approx. 55 mm (2.2")

DIN 11864-1

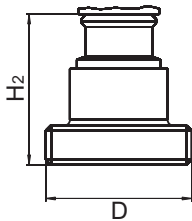

DN	PN	∅D	H ₂
25	40	52.4 mm (2.1")	Approx. 54 mm (2.1")
40	40	65.4 mm (2.6")	Approx. 54 mm (2.1")
50	40	78.4 mm (3.1")	Approx. 54 mm (2.1")
100	40	130.6 mm (5.1")	Approx. 54 mm (2.1")

DIN 11864-2

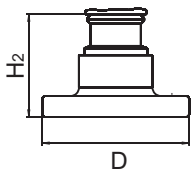

DN	PN	∅D	H ₂
25	40	70 mm (2.8")	Approx. 49 mm (1.9")
40	40	82 mm (3.2")	Approx. 49 mm (1.9")
50	40	94 mm (3.7")	Approx. 49 mm (1.9")
100	40	159 mm (6.3")	Approx. 49 mm (1.9")

DIN 11864-3

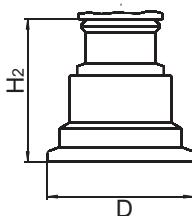

DN	PN	∅D	H ₂
25	40	50,5 mm (2")	Approx. 49 mm (1.9")
40	40	64 mm (2.5")	Approx. 49 mm (1.9")
50	40	77,5 mm (3.1")	Approx. 49 mm (1.9")
100	40	130 mm (5.1")	Approx. 49 mm (1.9")

Tri-Clamp as per DIN 32676

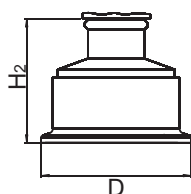

DN	PN	∅D	H ₂
20	40	34 mm (1.3")	Approx. 53 mm (2.1")
25	40	50.5 mm (2")	Approx. 53 mm (2.1")
32	40	50.5 mm (2")	Approx. 53 mm (2.1")
40	40	50.5 mm (2")	Approx. 53 mm (2.1")
50	40	64 mm (2.5")	Approx. 53 mm (2.1")
65	40	91 mm (3.6")	Approx. 53 mm (2.1")
80	40	106 mm (4.2")	Approx. 53 mm (2.1")
100	40	119 mm (4.7")	Approx. 53 mm (2.1")

Other connections

Varivent® connector

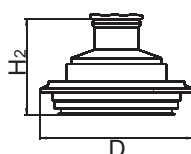

DN	PN	∅D	H ₂
25-32	40	66 mm (2.6")	Approx. 53 mm (2.1")
40-125	40	84 mm (3.3")	Approx. 53 mm (2.1")

12.5 Bioconnect/Biocontrol

Bioconnect™ connector

Bioconnect™ screw connector

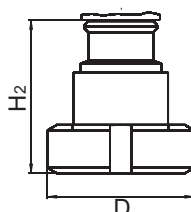

DN	PN	∅D	H ₂
25	40	55 mm (2.2")	Approx. 57 mm (2.2")
50	40	82 mm (3.2")	Approx. 57 mm (2.2")
100	40	145 mm (5.7")	Approx. 57 mm (2.2")

Bioconnect™ flange connector

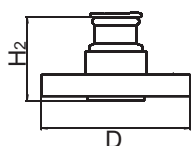

DN	PN	∅D	H ₂
25	40	85 mm (3.3")	Approx. 48 mm (1.9")
50	40	110 mm (4.3")	Approx. 48 mm (1.9")
100	40	175 mm (6.9")	Approx. 48 mm (1.9")

Bioconnect™ clamp connector

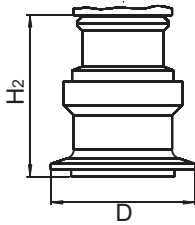

DN	PN	∅D	H ₂
25	40	50,5 mm (2")	Approx. 48 mm (1.9")
40	40	50,5 mm (2")	Approx. 48 mm (1.9")
50	40	64 mm (2.5")	Approx. 48 mm (1.9")
65	40	91 mm (3.6")	Approx. 48 mm (1.9")
80	40	106 mm (4.2")	Approx. 48 mm (1.9")
100	40	119 mm (4.7")	Approx. 48 mm (1.9")

Other connections

Biocontrol™ connector

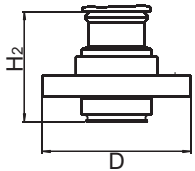

DN	PN	∅D	H ₂
25	40	64 mm (2.5")	Approx. 48 mm (1.9")
50	40	90 mm (3.5")	Approx. 48 mm (1.9")
100	40	120 mm (4.7")	Approx. 48 mm (1.9")

Connect S™ flanged joint

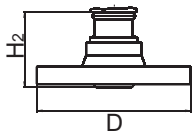

DN	PN	∅D	H ₂
25	40	85 mm (3.3")	Approx. 47 mm (1.9")
32	40	95 mm (3.7")	Approx. 47 mm (1.9")
40	40	100 mm (3.9")	Approx. 47 mm (1.9")
50	40	110 mm (4.3")	Approx. 47 mm (1.9")
65	40	140 mm (5.5")	Approx. 47 mm (1.9")
80	40	150 mm (5.9")	Approx. 47 mm (1.9")
100	40	175 mm (6.9")	Approx. 47 mm (1.9")

12.6 PMC Style

Connections for the paper industry

PMC Style Standard

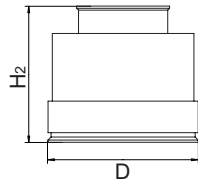

DN	PN	ØD	H ₂
-	-	40.4 mm (1.6")	Approx. 36.8 mm (1.4")
M44x1.25 cap nut			

PMC-Style Minibolt

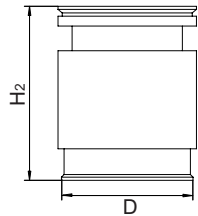

DN	PN	ØD	H ₂
-	-	26.3 mm (1")	Approx. 33.1 mm (1.3")

A

Appendix

A.1 Certifications

The certifications are enclosed as a loose collection of operating instructions or on CD..

A.2 Literature and catalogs

Nr.	Title	Publisher	Order no.
/1/	PNO interest group PROFIBUS-PA	PNO Technologiefabrik Haid-und-Neu-Str. 7 D-76131 Karlsruhe	2.091
/2/	SIMATIC package field technology	Siemens AG	Internet address: http://www.ad.siemens.de:8080/virlib/html_00/doc/index.htm over: Profibus descriptions (free of charge) / system description / PA system description in German
/3/	ST PI catalog PROFIBUS and AS Interface Components on the field bus	Siemens AG	E86060-K4660-A101-A3
/4/	Catalog ST 50 SIMATIC SIMATIC S5/PC/505 Automation systems	Siemens AG	E86060-K4650-A111-A7
/5/	Catalog ST 70 SIMATIC S7/M7/C7 automation systems	Siemens AG	E86060K4670A111A4
/6/	Catalog ST 80 SIMATIC HMI operation and observation products	Siemens AG	E86060K4680A101A5
/7/	Catalog IK 10 SIMATIC NET communications networks	Siemens AG	E86060K6710A101A7

Nr.	Title	Publisher	Order no.
/8/	Catalog ST PCS 7 SIMATIC SIMATIC PCS 7 process control system	Siemens AG	E86060K4678A111A2

A.3 Overview of status codes

Table A-1 Status code

Digital display	Hex	Configured measured value source	PDM display	Cause	Measure
	80	Electronics temperature Sensor temperature, raw pressure value, secondary variable 1, secondary variable 2, measured value (primary variable), secondary variable 3, output, totalizer output,	---	Normal operation	---
G_132	84	Electronics temperature Sensor temperature, raw pressure value, secondary variable 1, secondary variable 2, measured value (primary variable), secondary variable 3, output, totalizer output,	Good, update.event	A parameter relevant to the behavior of the slave was changed. The display goes off after 10 sec.	Note to the control system.
G_137	89	Output, totalizer output	Good, warning limit exceeded	Lower configured warning limit violated.	Correct error through user program.
G_138	8A	Output, totalizer output	Good, warning limit exceeded	Upper configured warning limit violated.	Correct error through user program.
G_141	8D	Electronics temperature, output, totalizer output,	Good, alarm limit violated	Lower configured alarm limit violated.	Correct error through user program.
G_142	8E	Electronics temperature, output, totalizer output,	Good, alarm limit violated	Upper configured alarm limit violated.	Correct error through user program.
G_164	A4	Raw pressure value, secondary variable 1, secondary variable 2, measured value (primary variable), secondary variable 3, output, totalizer output,	Good, Service required	Service interval expired: Calibrate or service.	Service, calibration of the electronics, or service of the sensor cell is necessary.
U_071	47	Output	Unsure, Last usable value, value constant	Input condition "fail safe" is fulfilled, the parameterized safety setting is set to "keep	Check the data measurement.

Digital display	Hex	Configured measured value source	PDM display	Cause	Measure
				last valid value".	
U_072	48	Totalizer output	Unsure, Replacement value	Use of the totalizer block if the measured value status is "Bad" and the parameterized safety setting is "Safe operation". The summed value changes. Failure behavior = safe operation.	Check the data measurement.
U_075	4B	Output, totalizer output	Unsure, Replacement value, value constant	Value is not an automatic measurement value. A parameterizable, static replacement value or preset value is marked in this manner.	Check the data measurement.
U_079	4F	Output, totalizer output	Unsure, Initial value, value constant	An initial value is written to the device memory after startup.	Throw away the value in the application program.
U_080	50	Raw pressure value, secondary variable 1, secondary variable 2, measured value (primary variable), secondary variable 3, output, totalizer output,	Unsure, Value inexact	Impermissible operating parameter or service alarm.	Check the operating parameters, e.g. the permissible ambient temperature. Immediate service required.
U_081	51	Raw pressure value, secondary variable 1, secondary variable 2, measured value (primary variable), secondary variable 3, output, totalizer output,	Unsure, Value inexact, limit value violated	Lower nominal range measurement limit violated (<0%).	Increase the pressure in the positive direction.
U_082	52	Raw pressure value, secondary variable 1, secondary variable 2, measured value (primary variable), secondary variable 3, output, totalizer output,	Unsure, Value inexact, limit value violated	Upper nominal range measurement limit violated (<100%).	Reduce the pressure.
B_000	00	Output (cyclical data only), totalizer output (cyclical data only)	Bad	Used if no other information is available. Device does not exist or cyclical connection is interrupted.	-

Digital display	Hex	Configured measured value source	PDM display	Cause	Measure
B_004	04	Raw pressure value, secondary variable 1, secondary variable 2, measured value (primary variable), secondary variable 3, output, totalizer output,	Bad, Configuration error	Calibration span too small.	Repeat the calibration procedure with pressure values which are farther apart.
B_011	0B	Secondary variable 3	Bad, not connected, value constant	Variable is not calculated,	Correct the "transmitter type" setting.
B_012	0C	Raw pressure value, secondary variable 1, secondary variable 2, measured value (primary variable), secondary variable 3, output, totalizer output,	Bad, Device error	Device has an irreparable error	Replace the electronics.
B_015	0F	Raw pressure value, secondary variable 1, secondary variable 2, measured value (primary variable), secondary variable 3, output, totalizer output,	Bad, Device error, value constant	Device has an irreparable error	Replace the electronics.
B_016	10	Raw pressure value, secondary variable 1, secondary variable 2, measured value (primary variable), secondary variable 3, output, totalizer output,	Bad, Sensor error	Sensor indicates an error.	Have a service technician check the sensor.
B_017	11	Raw pressure value, secondary variable 1, secondary variable 2, measured value (primary variable), secondary variable 3, output, totalizer output,	Bad, Sensor error, limit value violated	Negative pressure too high. Lower control limit violated (<-20% of nominal measurement range).	Increase the pressure in the positive direction.
B_018	12	Raw pressure value, secondary variable 1, secondary variable 2, measured value (primary variable), secondary variable 3, output, totalizer output,	Bad, Sensor error, limit value violated	Positive pressure too high. Upper control limit violated (>120% of nominal measurement range).	Reduce the pressure.
B_031	1F	Output, totalizer output	Bad, Out of service, value constant	Function block was placed out of service with a target mode command. A parameterized safety value is output.	For normal operation, reset the target mode to AUTO.

¹⁾ Only if the failure behavior of the analog input function block is set to "The incorrectly calculated measured value is on output".

²⁾ Only if the failure behavior of the totalizer function block has been set to "Operation".

See also

Status (Page 8-4)

Error display (Page 6-4)

Status display (Page 6-6)

List of Abbreviations/Acronyms

B.1 Abbreviations for pressure transmitter overall

List of abbreviations

Table B-1 Variables

Abbreviation	In full	Meaning
OUT	Output	
PRIM	Primary variable	
SEC	Secondary variable	
SENS	Pressure raw value	
TMP E	Electronics temperature	
TMP S	Sensor temperature	
TOTAL	Totalizer output	

Table B-2 Units

Abbreviation	In full	Meaning
bar a	bar absolute	Unit of pressure for absolute pressure
bar g	bar gauge	Unit of pressure for gauge pressure
lb	Pound (German: Pfund)	Unit of weight
psi a	psi absolute	Unit of pressure for absolute pressure
psi g	psi gauge	Unit of pressure for gauge pressure

Table B-3 Other abbreviations

Abbreviation	In full	Meaning
CLASS		Name for nominal pressure measured in psi
PED	Pressure equipment directive	
DN	Diameter Nominal	Nominal diameter measured in mm
DP	Decentralized peripherals	Protocol for the transmission of information between field device and automation system over the PROFIBUS.
FDE	Failure shutdown electronics	
FISCO	Fieldbus Intrinsic Safety	

List of Abbreviations/Acronyms

B.1 Abbreviations for pressure transmitter overall

Abbreviation	In full	Meaning
	Concept	
GSD	Device master data	
HART	Highway Addressable Remote Transducer	Standard protocol for the transmission of information between field device and automation system
F&B	Food and beverage industry	
PA	Process automation	Protocol for the transmission of information between field device and automation system over the PROFIBUS.
PDM	Process Device Manager	
PN	Pressure Nominal	Nominal pressure measured in bars
PNO	PROFIBUS user organization	
PROFIBUS	Process Field Bus	Manufacturer-independent standard for the networking of field devices, e.g. PLC, drives, or sensors. PROFIBUS can be used with the protocols DP or PA.
SELV	Safety Extra-Low Voltage Safety extra-low-voltage	

Glossary

Coupler

in PROFIBUS, connects the DP and PA segments. It has a fixed baud rate. The baud rate is 45.45 kbps (DP) to 31.25 kbps (PA).

Device master data

The control system finds the information necessary for establishing communications in the device master data (DMD).

Function block

A named block consisting of one or more inputs, outputs, and included parameters.

Function blocks represent the basic automation functions executed by an application in a way as independent as possible from the details of I/O devices and the network. Each function block processes input parameters using a specified algorithm and a set of internally stored parameters. They produce output parameters which are available for use inside the same function block application or by other function block applications.

GSD

→ *Device master data*

Link

is a coupler with a variable baudrate. The maximum baud rate is 12 Mbps (DP) to 31.25 kbps (PA).

Zero point adjustment

After the following functions, the measurement range is changed:

- Zero-point calibration (mode 7)
- LO calibration (mode 19)
- HI calibration (mode 20)

If you have executed one of these functions, the measurement range has changed. This changed, remaining measurement range is called the zero-point adjustment. The value displayed by the device in mode 18 is a positive pressure.

Index

A

- Address
 - PROFIBUS, 6-17
- Ambient temperature, 11-3, 11-7
 - Influence, 11-2, 11-7
- Arrow display, 6-5
- AUTO, 7-10
- Auxiliary power, 11-4

B

- Bus address, 6-17

C

- C2 connection, 8-6
- Calibration
 - HI, 6-23
 - LO, 6-22
 - Sensor, 7-26
- Certificate, A-1
- Certification, A-1
- Configuration, 8-1
- Coupler, 3-6, 3-15

D

- Damping, 7-9
- Data consistency, 8-1
- data transmission
 - acyclic, 8-6
 - cyclical, 8-1
- Data transmission
 - Floating point representation, 8-3
- Decimal point, 6-20
- Degree of protection, 3-5
- Device master data, 3-13, 1
- Device operation type, 6-18
- Diagnostic information
 - Transmission, 8-4
- Diagnostic messages, 8-5

- Digital display, 3-4, 7-3
 - Error message, 10-1
 - Status code, A-2

E

- Electromagnetic compatibility, 11-3, 11-7
- EMC, 11-3, 11-7
- Error message, 10-1

F

- Firmware, 3-5
- FISCO, 3-15
- Flange, 4-6
- Function block
 - Analog input, 7-9, 7-15
 - Totalizer, 7-10

G

- GMD file, 6-19
- GSD, 3-13, 1
- GSD file
 - Internet address, 8-1

K

- Keypad lock, 6-11, 7-17
 - remove, 6-12

L

- LCD, 3-4
- Limits
 - Alarm, 7-18
 - Warning, 7-18
- Link, 3-7, 3-15
- Lock mode, 6-11

- M**
- Master
 - Class 2 master, 8-6
 - Class-1 master, 3-13, 8-1
 - Class-2 master, 3-13
- Mode
 - 10, 6-11
 - 13, 6-12
 - 14, 6-14
 - 15, 6-17
 - 16, 6-18
 - 17, 6-20
 - 18, 6-21
 - 19, 6-21
 - 20, 6-23
 - 4, 6-9
 - 7, 6-10

- N**
- Nameplate, 3-4

- O**
- Order no., 3-5
- Output scaling, 7-9, 7-12

- P**
- Parameter
 - Transmitter type, 6-12
- PDM display
 - Error message, 10-1
 - Status code, A-2
- Position correction, 6-10
- PROFIBUS, 3-12, 7-1
 - Automation system, 3-13
 - Communication structure, 7-1
 - Connection, 3-14
 - DP, 3-12
 - Eigenschaft, 3-14
 - Functions, 7-10
 - Operation, 7-10
 - PA, 3-12
 - Profile, 3-14
 - Setting the address, 8-1
 - Strand, 3-14
 - Topology, 3-12

- R**
- Resetting
 - Delivery state, 7-28
 - Factory settings, 7-28
- Restart, 7-28

- S**
- Scaling
 - Measured value, 7-9, 7-12
- SELV, 3-15
- Serial number, 3-5
- Setting
 - Fill level measurement, 7-12
 - Height measurement, 7-12
 - Mass measurement, 7-14
 - Volume measurement, 7-13
- Simulation, 7-9, 7-23
- Status, A-2
- Status, 8-4
- Status code, A-2
- Status code, 8-4

- T**
- Terminating resistor T, 3-14
- Test connector, 6-6
- Transducer block
 - for electronics temperature, 7-2, 7-8
 - for pressure, 7-2

- U**
- Unit
 - for level, 6-16
 - for mass, 6-16
 - for pressure, 6-15
 - for temperature, 6-16
 - for user-specific, 6-17
 - for volume, 6-15

- V**
- Variable, 6-12

- W**
- Warm start, 7-28
- Watchdog, 8-5
- Write protection, 6-11
 - remove, 6-12

Z

Zero point calibration, 6-10, 6-21

Zero point adjustment, 6-7, 6-21



A5E00414588

A5E00414588-02

Siemens Aktiengesellschaft

Automation and Drives
Process Instrumentation and Analytics
76181 KARLSRUHE
GERMANY

www.siemens.com/processinstrumentation